

2002

Scenic Traveler 1-800 568-2210

Slinger, WI.

Flagstaff™

Model 205 - 2,317 pounds

Camping Trailers

11 gal. water holding tank

OWNER'S MANUAL

FOREST RIVER CAMPERS LIMITED WARRANTY

FOLD DOWN CAMPING TRAILERS

SUMMARY OF WARRANTY

Forest River Campers (Forest River), warrants only to the original consumer (You) of every Forest River Fold Down Camping Trailer that the trailer is free from defects in materials and workmanship under normal noncommercial use and service for 12 months from the original date of purchase. Forest River further warrants to the original purchaser that the roof, tent and frame are free from substantial defects in material and workmanship attributable to Forest River for five (5) years for parts and three (3) years for labor and parts, from the date of purchase under normal use and service effective with 1995 models. This warranty does not apply to any defect in the aesthetics or physical appearance of the unit, nor to normal deterioration of the soft trim and appearance items due to wear and exposure.

HOW TO OBTAIN WARRANTY SERVICE

Defects in materials and workmanship of the trailer during the first 12 months will be repaired free of charge if the unit is returned with transportation charge prepaid to an authorized Forest River dealer or to Forest River, with return transportation at your expense. Substantial defects in material or workmanship of the roof, tent or frame of the trailer during the first three years of the five year warranty period will be repaired free of charge if the part is returned with transportation charges prepaid to an authorized Forest River dealer or to Forest River, with return transportation at your expense. For the remainder of the five (5) year warranty period, warranty parts will be replaced, but necessary labor will be charged. If a factory or authorized service center is not available in your area, call direct to Forest River, (219) 533-5934 to arrange prompt and proper repairs to your trailer to avoid possible delays.

EXCLUSIONS

Forest River assumes no responsibility or liability for defects in workmanship or operation of separately warranted products. These products may be warranted by the individual manufacturers and a copy of their warranty has been included in your owner's packet. Separately warranted products will not be serviced, repaired or replaced by Forest River. If service or parts are required for these products, refer to the furnished list of factory authorized service centers. If the list is not available for the particular products, write or call the manufacturer concerned to obtain the location of the nearest service center.

Forest River does not warrant components manufactured by others, including, but not limited to tires, appliances, equipment, ranges, ovens, furnaces, batteries, axles, hubs, bearings, power converters, refrigerators, burners, floors, and brake systems. These parts may or may not be warranted by their manufacturers and Forest River, however, assumes no obligations with regard to them.

This unit was expressly designed for use as a recreational vehicle and is not intended for use as a full-time stationary residence. Forest River makes no warranty with regard to normal and routine condensation.

Snow loads must be removed from the roof to avoid damage to the roof.

This warranty shall not apply to normal maintenance, such as greasing wheel bearings, tightening lug nuts, keeping the areas where extrusions meet panels sealed, etc. that the vehicle will require nor to any damages arising from abuse or the failure to have such maintenance performed.

Fabric items such as canvas, canopies, window screening, vinyl windows, cushion and mattress covers, are not warranted against leakage, tears, punctures, shrinkage, fading or soiling but are warranted only as against defective workmanship and material. Installation of a roof air conditioner must be done at the designated area on the roof, by an approved Forest River dealer, or the roof, lifter system, and related components will not be warranted.

The vehicle is a cargo trailer and you are advised to observe the recommended gross weight limit. **COMMERCIAL USE OR RENTALS OF THIS VEHICLE AND ABUSE, NEGLIGENCE, OR OPERATION OVER UNIMPROVED ROADS WILL VOID THIS WARRANTY. FOREST RIVER MAKES NO WARRANTY WITH REGARD TO ANY PRODUCT NOT REGISTERED AND NORMALLY USED IN THE UNITED STATES OR CANADA.**

DISCLAIMER OF DAMAGES

YOU AND ANY OTHER USER OF FOREST RIVER PRODUCTS AND ANY PERSON TO WHOM THIS UNIT IS TRANSFERRED, AND ANY PERSON WHO IS AN INTENDED OR UNINTENDED BENEFICIARY OF THIS UNIT SHALL NOT BE ENTITLED TO ANY CONSEQUENTIAL OR INCIDENTAL DAMAGES, INCLUDING WITHOUT LIMITATION, LOSS OF USE OF THE UNIT, INCONVENIENCE, FOOD, LODGING, DAMAGE TO PERSONAL PROPERTY, LOST INCOME OR EARNINGS. SOME STATES DO NOT ALLOW THE EXCLUSION OR LIMITATION OF INCIDENTAL OR CONSEQUENTIAL DAMAGES, SO THE ABOVE LIMITATION MAY NOT APPLY TO YOU.

DISCLAIMER AND LIMITATIONS OF IMPLIED WARRANTIES

FOREST RIVER LIMITS ALL IMPLIED WARRANTIES OF FITNESS FOR A PARTICULAR PURPOSE AND MERCHANTABILITY TO THE WARRANTY PERIOD OF ONE YEAR. NO WARRANTIES, EXPRESS OR IMPLIED, EXTEND BEYOND THE ONE YEAR WARRANTY PERIOD. NO PERSON HAS THE AUTHORITY TO EXTEND, ENLARGE, OR MODIFY THIS WARRANTY. NO ACTION TO ENFORCE THIS WARRANTY MAY BE COMMENCED MORE THAN SIX MONTHS AFTER EXPIRATION OF THE WARRANTY PERIOD.

SOME STATES DO NOT ALLOW LIMITATIONS ON HOW LONG AN IMPLIED WARRANTY MAY LAST SO THE ABOVE LIMITATION MAY NOT APPLY TO YOU. THIS WARRANTY GIVES YOU SPECIFIC LEGAL RIGHTS, AND YOU MAY ALSO HAVE OTHER RIGHTS WHICH VARY FROM STATE TO STATE.

FOREST RIVER'S OBLIGATION

Forest River will remedy substantial defects in materials and workmanship caused by Forest River. Forest River shall elect to remedy the defect from among the following: repair, replacement or refund. Forest River may not elect refund unless you agree or Forest River is unable to provide replacement and repair is not commercially practicable or cannot be timely made. Warranty performance can only be obtained at Forest River's authorized dealers and service centers and from Forest River. All costs incurred in transporting this Fold Down Camping Trailer for warranty service shall be borne by you. Forest River shall remedy the defect within a reasonable time, not to exceed sixty (60) days after delivery by you. All of Forest River's expenses in remedying the defect shall be borne by Forest River.

YOUR OBLIGATIONS

You must complete and return the owner's registration **within (10) ten days of purchase to validate this Warranty.** The return of this registration is a condition precedent to warranty coverage; failure to return the completed card to Forest River will invalidate this warranty. You shall deliver this Fold Down Camping Trailer for warranty service within a reasonable time after discovery of the defect and in no event after expiration of the Warranty period, as set forth above. All expenses incurred by you in obtaining warranty service shall be borne by you. You can obtain a list of persons authorized to perform warranty service by contacting Forest River at the address below.

PARTS AND DESIGN CHANGES

Forest River may make parts and design changes from time to time without notice and repairs or replacements may be made with new or different parts.

WARRANTY REGISTRATIONS

Your warranty registration records should be completed and delivered to the manufacturers of component parts, as they may be a condition of this warranty. **THIS FOREST RIVER WARRANTY IS VOID UNLESS YOUR WARRANTY REGISTRATION IS RETURNED TO FOREST RIVER.**

FOREST RIVER, INC.

P.O. BOX 124 • GOSHEN, INDIANA 46527

PHONE: (219) 533-5934

FOREST RIVER CAMPERS

LIMITED LIFETIME WARRANTY

FOLD DOWN CAMPER LIFTER SYSTEM

SUMMARY OF WARRANTY

Forest River, extends to the original retail purchaser (You) a limited warranty on its lifter system in Forest River recreational vehicles against defects in material or workmanship for the lifetime of the recreational vehicle.

COMPANY'S OBLIGATIONS

If the lifter system is determined to be defective during the warranty term, Forest River will remedy the defect without charge within a reasonable time after receipt of written notice, either by repair or replacement. Warranty service may be obtained from Forest River or its authorized dealers, or persons designated by Forest River. In the event you have a defective lifter system repaired by an unauthorized service person and said repairs are covered by this Warranty, Forest River shall be liable only for costs of those repairs up to the amount that Forest River would have incurred if Forest River or an authorized dealer had made the repairs.

Warranty performance will commence within a reasonable time after Forest River's receipt of written notice of the defect and will be completed within a reasonable time, subject to availability of parts and scheduling.

ITEMS EXCLUDED FROM WARRANTY

This warranty does not cover defects caused by:

1. Negligence in operation and maintenance.
2. Misuse of lifter system
3. Damage not resulting from defect or malfunction (act of God).
4. Any damage whatever is caused by or related to any alteration of a Forest River lifter system.
5. Claims relating to unauthorized repairs, damage or defects.

PURCHASER'S OBLIGATION

You shall give written notice to Forest River at the address set forth herein within a reasonable time after discovery of the defect. This written notice should contain the following information:

1. Your name and mailing address.
2. Proof of date of purchase.
3. Model, year and serial number of the unit.
4. Name and address of dealer from whom unit was purchased.
5. Description of the defect.

All costs incurred by you in transporting the Forest River lifter system for warranty service shall be borne by you. No action to enforce this Warranty shall be commenced later than three (3) months after the expiration of the warranty period.

DISCLAIMER OF CONSEQUENTIAL OR INCIDENTAL DAMAGES

REPAIR OR REPLACEMENT UNDER THIS WARRANTY IS YOUR EXCLUSIVE REMEDY. FOREST RIVER SHALL NOT BE LIABLE FOR ANY INCIDENTAL OR CONSEQUENTIAL DAMAGES RESULTING FROM ANY DEFECT IN THE FOREST RIVER LIFTER SYSTEM. SOME STATES DO NOT ALLOW THE EXCLUSION OR LIMITATION OF INCIDENTAL OR CONSEQUENTIAL DAMAGES SO THE ABOVE LIMITATION OR EXCLUSION MAY NOT APPLY TO YOU.

LIMITATION AND DISCLAIMER OF IMPLIED WARRANTIES

FOREST RIVER EXPRESSLY LIMITS ALL IMPLIED WARRANTIES TO THE WARRANTY PERIOD. FOREST RIVER EXPRESSLY DISCLAIMS WITH RESPECT TO THE FOREST RIVER LIFTER SYSTEM ALL IMPLIED WARRANTIES OF MERCHANTABILITY AND ALL IMPLIED WARRANTIES OF FITNESS FOR A PARTICULAR PURPOSE AFTER EXPIRATION OF THE WARRANTY PERIOD. THERE IS NO WARRANTY OF ANY NATURE MADE BY FOREST RIVER BEYOND THAT CONTAINED IN THIS WARRANTY. NO PERSON HAS AUTHORITY TO ENLARGE, AMEND, OR MODIFY THIS WARRANTY.

SOME STATES DO NOT ALLOW LIMITATIONS ON HOW LONG AN IMPLIED WARRANTY LASTS SO THE ABOVE LIMITATION MAY NOT APPLY TO YOU.

THIS WARRANTY GIVES YOU SPECIFIC LEGAL RIGHTS AND YOU MAY ALSO HAVE OTHER LEGAL RIGHTS WHICH VARY FROM STATE TO STATE.

PARTS AND DESIGN CHANGES

Forest River may make parts and design changes from time to time without notice and repairs or replacements may be made with new or different parts.

All inquiries regarding this Warranty should be sent to:

FOREST RIVER, INC.
P.O. BOX 124 • GOSHEN, INDIANA 46527
PHONE: (219) 533-5934

Forest River Camping Trailers

Table of Contents

Foreword	3	Folding Clothes Hanger	17
Serial Number, Decals, and Data Plates	3	High-Rise Kitchen Counter	17
Manufacturer's Warranties	4	Flip-Up Countertop Extension	18
Safety	4	Pull-Out Kitchen	18
Care and Maintenance	4	Inside/Outside Range	18
General Information	4	Dinette	18
Exterior Maintenance	4	Gaicho	18
Tent Maintenance	5	Take Down Procedure	18
Crank-up Lift System Maintenance	5	LP Gas System	19
Interior Maintenance	7	General Information	19
Wintertime Use	7	LP Gas Containers	19
Winter Storage	8	Filling LP Gas Containers	20
Safe Operating Practices	8	LP Gas Regulator	20
Rules for Trailer Towing	8	Regulator Freeze-Up	21
Periodic Maintenance Chart	9	LP System Hoses and Fittings	21
Safety Regulations for LP Gas System	10	Checking LP System for Leaks	22
Fire Safety	10	LP Gas Safety Precautions	22
Fire Extinguisher	11	Electrical System	23
Load Limits & Weight Distribution	11	12 Volt System	23
Towing Vehicle Requirements	13	12 Volt Bulbs and Fuses	23
Hitch	13	110 Volt System	23
Wiring	13	Battery Box and Charger	24
Hitching	13	Ground Fault Circuit Interrupter	24
Safety Chains	13	Water and Drainage System	24
Electrical Hook-Up	14	Fresh Water Tank	24
Brakes	14	Water Pump	25
Driving and Towing Tips	14	Filling the System	25
Backing Up	14	Drainage	25
Tires and Lug Nuts	15	Cassette Porta Potti	25
Changing a Tire	15	Sanitizing Potable Water System	25
Campsite Selection and Set-Up	16	Draining the System	25
Set-Up Tips and Precautions	16	Water System Maintenance & Troubleshooting	26
Setting Up the Exterior	16	Appliances	26
Setting Up the Bunks	17	General Information	26
Entryway Set-Up	17	Range	26
Steps	17	Water Heater	26
Setting Up the Interior	17	Furnace	27
Sliding Wardrobe	17	Refrigerator	27

The following note is added as a requirement of the National Highway Traffic Safety Administration (NHTSA)

If you believe that your vehicle has a defect which could cause a crash or could cause injury or death, you should immediately inform the National Highway Traffic Safety Administration (NHTSA) in addition to notifying Forest River Campers.

If NHTSA receives similar complaints, it may open an investigation, and if it finds that a safety defect exists in a group of vehicles, it may order a recall and remedy campaign. However, NHTSA cannot become involved in individual problems between you, your dealer, or Forest River Campers.

To contact NHTSA, you may either call the Auto Safety Hot-line toll-free at 1-800-424-9393 (or 366-0123 in Washington, D.C. area) or write to: NHTSA, U.S. Department of Transportation, Washington, D.C. 20590. You can also obtain other information about motor vehicle safety from the Hot-line.



**A Symbol Which Means
BE ALERT!
YOUR SAFETY IS INVOLVED!**

FOREWORD

Thank you for selecting a **FOREST RIVER** camping trailer. Welcome to the life-style that it will provide you. You will have the freedom to travel and enjoy camping fun whenever you wish.

Your **FOREST RIVER** camping trailer complies with the requirements set forth by the Recreational Vehicle Institute Association, as well as various other federal and state agencies.

Items of quality such as this camping trailer will always respond best to considerate treatment and care. Therefore, before using it, we suggest that you review the entire contents of this manual. The material within has been prepared in sufficient detail to be of maximum assistance, and the illustrations will be of considerable help when you are getting to know your new camper.

Review this manual with your dealer. He can answer any questions you may have. Read all the literature supplied with your new camping trailer, including all warranty and warranty registration information. Be sure to validate warranties by completing and mailing the individual warranty cards for each of the respective manufacturers.

CHECK TO MAKE SURE THAT YOUR DEALER HAS COMPLETED AND RETURNED YOUR FOREST RIVER WARRANTY REGISTRATION FORM.

Be sure your dealer has installed the LP gas container bracket, as well as the LP gas container and regulator. Check that the connection has been made between the regulator and the LP gas manifold. Have your dealer explain the operation of filling the LP container as well as how to check the system for leaks.

Always keep this owner's manual with the camper for easy reference, making sure to observe and follow all instructions and warnings associated with its use. Remember, accidents are caused by the failure of some individual to observe simple and fundamental safe rules or precaution. Accidents can be prevented by recognizing the cause of the accidents, and doing something about it before the accident occurs. A careful owner is the best insurance against an accident.

THIS OWNER'S MANUAL IS AS CURRENT AS POSSIBLE AT THE TIME YOUR CAMPING TRAILER WAS PRODUCED. HOWEVER, PRODUCTS ARE CONTINUALLY BEING UPGRADED AND IMPROVED. BECAUSE OF THIS, SOME DIFFERENCES MAY OCCUR BETWEEN THE DESCRIPTION IN THIS MANUAL, AND THE PRODUCT IN YOUR CAMPER. IF THIS OCCURS, FOLLOW THE COMPONENT MANUFACTURER'S INSTRUCTIONS PROVIDED IN THEIR LITERATURE.

SOME OF THE PRODUCTS SHOWN IN THIS MANUAL MAY BE OPTIONAL EQUIPMENT NOT INCLUDED WITH YOUR CAMPER. ANY SPECIAL EQUIPMENT, MODIFICATIONS, OR ADDITIONS MADE BY OR AT THE REQUEST OF THE CUSTOMER, OR ANY SUBSEQUENT OWNER, WHETHER MADE AT THE FACTORY OR IN THE FIELD, ARE NOT COVERED IN THIS MANUAL. WE RESERVE THE RIGHT TO CHANGE THE CONSTRUCTION OR MATERIAL OF ANY PARTS AT ANY TIME WITHOUT INCURRING THE OBLIGATION TO INSTALL SUCH CHANGES ON DELIVERED UNITS.

Your camper has had a thorough inspection before it was shipped to the dealer. However, to insure your complete satisfaction, the dealer will perform an inspection of various components and operations of your camper before you take delivery. You should take the opportunity to walk through this inspection with your dealer. This will help make you familiar with the camper and its components, while at the same time providing you with the assurance of everything being in proper working order. If you are not already familiar with trailer towing, go on a test drive with your dealer. Ask any questions you may have at this time.

This camping trailer has been designed for short term and recreational use. It was not designed to be used as a permanent dwelling. If you intend to use your camping trailer as a permanent dwelling, it could cause your drapes, upholstery, and interior surfaces to deteriorate prematurely. This premature damage and wear caused by permanent residency, may under the terms of **FOREST RIVER'S** warranty, be considered abnormal and abusive, and **COULD REDUCE YOUR WARRANTY COVERAGE.**

Should a problem develop for which you need assistance, contact your **FOREST RIVER** dealer. If the problem is with an appliance, check the appliance manufacturer's information supplied with the camping trailer for information regarding warranty work and/or location of appliance service centers.

If when traveling, you experience a breakdown or problem while your camper is under warranty, and an authorized service center or dealer is not available, make sure to contact your **FOREST RIVER** dealer by phone before having the work done at an independent service center. By notifying them, you will know what is covered under the terms of your warranty, as well as making them aware of your problem. Any parts that require replacement, and are covered under the terms of the **FOREST RIVER** warranty should be retained and returned to your local dealer along with your invoice. This way, they are able to check what has occurred, and also make sure you are properly reimbursed for your expenditures. Modifications made to the camping trailer without proper authorization can result in reduction or loss of warranty coverage. Please make sure to contact your dealer before making such changes.

Your satisfaction with your **FOREST RIVER** camping trailer is our aim. Please let us know how you feel about it. We really would enjoy hearing from you. We wish to thank you again for your purchase. May you have many years of carefree trailering.

SERIAL NUMBER, DECALS, AND DATA PLATES

The camping trailer serial number label is mounted on the front road side of the camper.

IMPORTANT: Always give model, year, and serial number information when ordering parts. Also, **FOREST RIVER** recommends that you keep a copy of this information separate from the camper in the event theft or vandalism requires you to supply a copy to the authorities.

Decals and date plates used throughout the camper aid in its safe and efficient operation; others give service instructions. Read all decals, data, and instruction plates before using your new camper. When any decal, data, or instruction plate is damaged, painted over, removed, etc.; it should be replaced.

MANUFACTURER'S WARRANTIES

The following list of manufacturers has been compiled to help you know which products on your camping trailer may have their own warranties. If you have any of these components on your camping trailer, be sure to check the literature supplied by the manufacturer to see if they require that you register your purchase with them to validate their warranty. These warranties usually apply only to the first owner of the camping trailer. **FOREST RIVER** recommends that you send the various warranty registration cards immediately before any time constraints on registration expire. Manufacturer's literature is contained in a separate packet furnished with the owner's manual on newly delivered units. Only those products and options which are on your camper will be included in this packet. You should go over this literature with your dealer during the pre-delivery inspection. Any shortages of literature should be reported to the dealer at that time.

APPLIANCES

Range	Suburban
Refrigerator	Dometic

ELECTRICAL

110/12V Converter	Magnetek
12V Water Pump	

WATER & DRAINAGE

Galley Pump	Leisure Components
Water Heater	Suburban
Toilet	Thetford

LP GAS

Regulator	Marshall Brass
Furnace	Suburban

MISCELLANEOUS

Axle	Al-Ko
------	-------

SAFETY

THE SAFETY ALERT SYMBOL  IS USED THROUGHOUT THIS MANUAL TO CALL ATTENTION TO WARNINGS WHERE VEHICLE DAMAGE OR POSSIBLE PERSONAL INJURY MAY BE INVOLVED.

CARE AND MAINTENANCE

GENERAL INFORMATION

Periodic maintenance and cleaning of your camping trailer is necessary to retain the dependability, safety, and appearance that will provide you with many seasons of trouble-free operation, as well as protecting your investment.

Make sure to read and follow all the maintenance tips and schedules that appear not only in this manual, but also in the information provided by the various component manufacturers. Keep good records of maintenance functions performed, and make sure to perform all owner obligations as may be required by the various component manufacturers to keep their warranties in force.

Preventative maintenance will pay for itself many times over by catching or preventing problems before they occur. Many repair costs are greatly increased due to the fact a small problem can begin

to affect other parts and systems of the camping trailer if left unattended.

If a situation arises involving a maintenance or cleaning activity for which you are not sure of the proper procedure, do not hesitate to contact your **FOREST RIVER** dealer.

It is our goal to keep you satisfied, and your camping trailer properly maintained. We want to know how you feel about your **FOREST RIVER** product, and any suggestions you may have are always welcome.

EXTERIOR

Fiberglass and Aluminum Siding - The care of fiberglass and aluminum siding is essentially the same as any automotive finish. Wash your camping trailer on a regular basis. Use warm water and a mild detergent to clean the finish. Take care to avoid spraying water directly into the furnace or refrigerator vents (if so equipped) when washing the camping trailer. Remove bird and tree sap droppings, insects, and tar as soon as possible to avoid staining of the finish.

NOTE: DO NOT use rubbing compound or any abrasive cleaner or cloth on the camping trailer. If using a tar and insect remover, make sure it is safe for use on painted surfaces.

It is important to note that any finish will deteriorate with time. Dulling and fading can be increased by exposure to extreme sunlight, air pollutants, and excessive moisture. Surface weathering of fiberglass does not change the strength of the fiberglass. Regular washing of exterior surfaces is the best insurance against surface deterioration such as fading, yellowing, or chalking.

If surface deterioration has occurred, check with your dealer for the steps required to restore the finish. Buffing or even painting may be necessary in extreme cases. Small cracks appearing in the fiberglass can be repaired by using a fiberglass filler. Allow the filler to harden, sand, and then repaint with gelcoat (check with your dealer for further instructions and product information).

Wash and wax fiberglass and aluminum surfaces at least three times a year with a standard liquid or paste wax. Make sure to follow the directions for use as outlined by the product manufacturer. Also clean and wax all metal extrusions when waxing camper sidewalls, to help avoid surface pitting. Make sure to wash and wax your camper out of the hot sun when exterior surfaces are cool. Storage of the camping trailer out of direct sun is also a primary way to help preserve exterior finishes.

NOTE: DO NOT use hand-held high pressure spray devices such as those at car washes which will damage the tape and painted surfaces on the camper. For heavily soiled spots, a VERY SOFT bristled brush can be used. Before using any cleaner or chemical on the camper, make sure to test a small area first. After washing, be sure to rinse the entire camper thoroughly to remove any soap residue that may remain, since it can stain the paint. Use towels or a chamois to dry the entire camper.

Physical damage to fiberglass or aluminum should be taken care of immediately to avoid moisture from entering through breaks and causing problems with interior walls and components. Cover breaks in the sidewall with plastic, sealing the edges with tape until proper repairs can be made.

NOTE: *DO NOT use rubbing compound or any abrasive cleaner or cloth on the camper. If using a tar and insect remover, make sure it is safe for use on painted surfaces.*

Seals and Adhesives - It is important to maintain the seals and adhesives of your camping trailer to prevent moisture from entering and destroying camping trailer components. When washing your camping trailer, inspect the seals and body moldings for signs of drying out and wear. Be aware that weather, sun, and road vibration will have an effect on seals, causing them to dry, crack, or separate.

On some campers, the roofs are aluminum, while on others they are fiberglass. You should check the condition of either type twice a year. Clean off all dirt, and check for cracks in the sealant around the vents and extrusions. Use a polyurethane sealant, or a marine type caulking to reseal.

NOTE: *It is very important to do this, to prevent moisture from entering the camper and causing rot, mold, and mildew. This is especially true for campers that are stored outside in the winter.*

If you are unsure what to look for, have your dealer instruct you, and also show you the correct method for renewing the seals. If you prefer, ask your dealer to perform seal maintenance for you.

⚠ WARNING: *Failure to maintain camping trailer seals through regular maintenance can lead to severe damage of camping trailer components, and may be considered abusive treatment under the terms of your camping trailer warranty.*

TENT MAINTENANCE

Tent Material - Tent materials have different characteristics than canvas. To provide you with many years of usage it is important to seal all stitched areas to prevent water damage.

1. Set up the camper as you would when camping. Make sure all windows are zipped closed, and the storm door window is closed and secure.
2. Remove all cushions and drapes and store them in a dry place.
3. Saturate all seams with water and go inside trailer to check all seams for leaks.
4. Allow the tent to dry completely, or wipe seams dry with a smooth white cloth before sealing.
5. Seal all seams with a wax candle or a special recommended seam sealer called: plasti-seam.
6. After you have sealed all stitching with one of the recommended products, be sure to replace all cushions and drapes which were stored in a dry area.

Care of Your Vinyl Tent - Some tents have the fabric coated with vinyl to make it easier to clean the exterior. Vinyl coated fabric cannot breathe; therefore, you'll notice that, at times, condensation will form on the fabric side and the tent would appear to be leaking. This condensation can be corrected by opening the zippered windows slightly to ventilate the interior of your camper.

ALWAYS VENTILATE AND DRY TENT, with bows and braces in place, **AS SOON AS POSSIBLE** after each exposure to moisture. **MILDEW** is always a result of negligence.

TO CLEAN THE OUTSIDE OF YOUR VINYL TENT use automotive vinyl cleaner.

DO NOT USE SOLVENTS AND DETERGENTS to clean your vinyl tent; it will cause damage to the finish.

CALL YOUR DEALER IF YOU HAVE OTHER CLEANING PROBLEMS.

ALL VINYL TENTS NEED TO GET WET ONE OR MORE TIMES TO SEAL THE NEEDLE HOLES. Your tent may leak the first time it gets wet. Do not be alarmed. The tent is sewn with special thread that swells up and seals the needle holes after it has been wet.

YOUR PLASTIC WINDOWS have a -20 cold crack. **YOU MUST NOT CRANK YOUR TENT UP IN EXTREME COLD TO THE MAXIMUM HEIGHT** in 0 weather. Your windows will shatter.

⚠ WARNING: *Do no use harsh chemicals or nonrecommended products that can react to tent and damage the material which could cause replacement.*

NOTE: *It is important to seal all seams before the first trip, and each year thereafter to prevent water damage to the interior of your camper. It is a good idea to include a wax candle in your field maintenance kit to seal a small leak that might develop while camping.*

⚠ WARNING: *If you use a candle for emergency lighting, be sure to observe proper fire safety precaution, and have your camper fire extinguisher nearby, and know how to use it. See the index for the location of fire extinguisher care and use.*

NOTE: *It is important to allow wet tent to dry completely before closing up the camper. If you must close up the camper with wet tent, be sure to protect all the cushions and drapes from dampness. Mold and mildew will form inside the camper if fabrics and surfaces are allowed to be stored in this way. Set up the camper again as soon as possible to allow it to air out and dry thoroughly.*

CRANK-UP LIFT SYSTEM

To ensure your limited warranty validation, you must perform or have performed a general maintenance inspection. Failure to provide service maintenance is readily recognized in the condition of the system.

Inspect and service yearly

1. Clean and recoat lifter posts externally with a rust prohibitive non-drying lubricant.
2. Grease zerks on front bottom and back top of master tube annually.
3. Lubricate springs annually by cranking roof to up position. At each junction of telescoping post lubricate with 90 weight oil into opening between two posts. Wipe off any excess oil on external portion of post to avoid tent damage.

Frame - Check the condition of the frame regularly. Keep it clean, and repaint as necessary to help avoid rust. It is especially important to keep underbody components clean, if you are towing the camping trailer in the winter in areas where road salts are used.

CRANK-UP LIFT SYSTEM

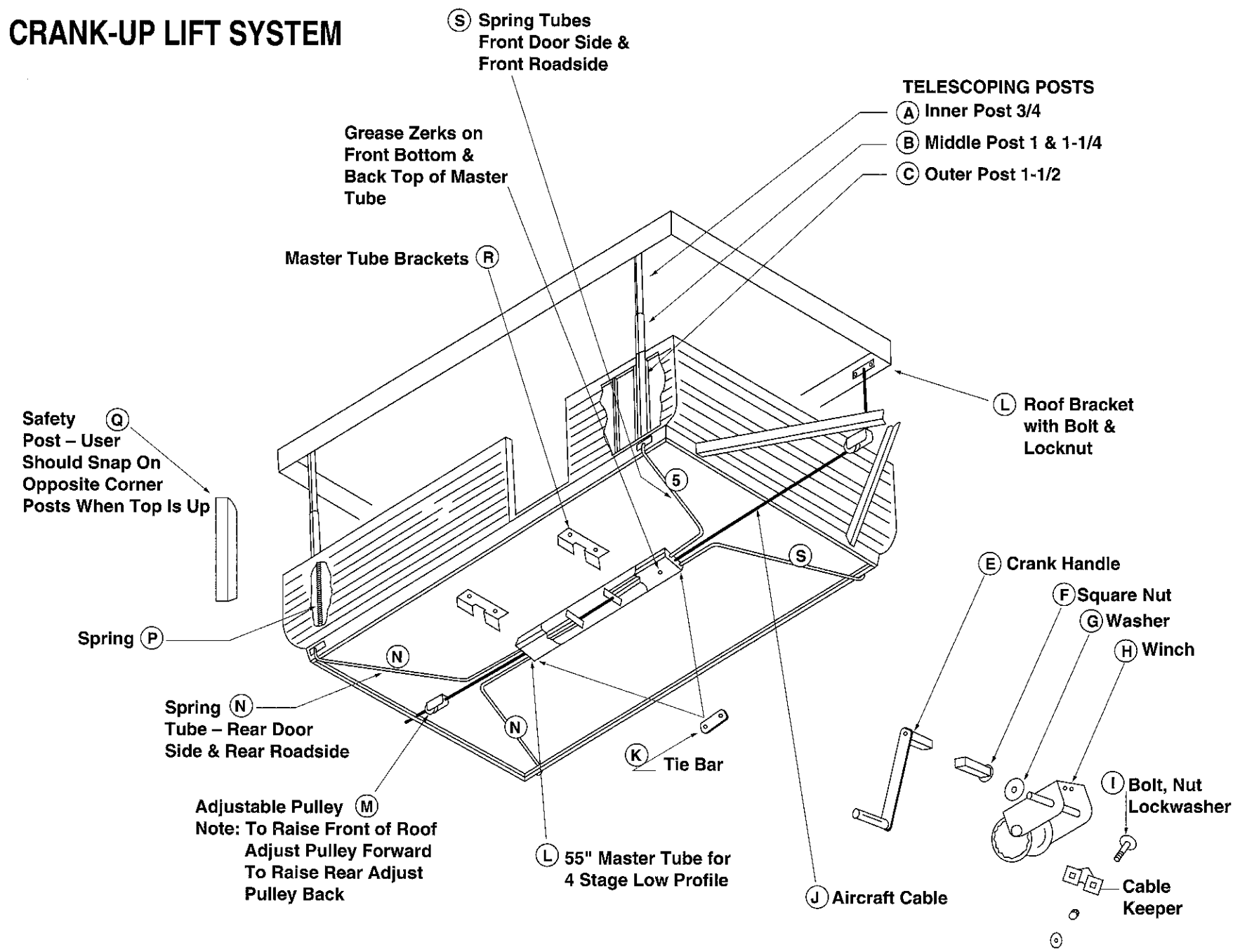

Wheels and Tires - In areas where hot sun constantly beats down on the camping trailer, shading the tires by covering can reduce tire sidewall cracks from forming. Spraying tire sidewalls with a silicone spray can also help keep them from drying out.

Check the pressure and condition of the tires as outlined elsewhere in this manual. Also check the condition of the wheels regularly. Keep clean, and repaint as necessary to avoid rust.

Check tightness and condition of lug bolts regularly. Torque to specifications and at intervals outlined elsewhere in this manual.

Brakes and Wheel Bearings - Check brake adjustment and linings regularly, and adjust as needed per the manufacturer's instructions. Also check the wheel bearings regularly and keep lubricated. If needed, repack with grease, and replace cotter pins.

Jack Post, Dolly Wheel, and Coupler - Keep threads and moving parts lubricated, and check condition regularly. Grease the release lever and coupler socket to insure proper operation and fit.

LP Gas System - The LP gas system should be checked regularly for leaks and road damage. The entire system, including regulator pressure, should be checked annually, or whenever you suspect a problem, by a qualified LP gas service technician using proper equipment. The method of checking the system for leaks, and LP gas safety precautions can be found elsewhere in this manual.

INTERIOR

Appliances, Sink, and Countertop - Clean the sink, countertop, and any appliances with hot soapy water or a good liquid cleaner. Avoid using abrasive cleaners. Do not place hot pots or pans directly on countertops, because they can loosen or scorch the surface.

Never use steel wool on the stainless steel sink, since the steel particles left in the sink can rust and become unsightly. Also, when cleaning stainless steel with a mild cleanser, rub gently with the grain, and rinse well. Rinse after each use and wipe dry. Remove food and ice from icebox or refrigerator at end of each trip. Prop door open slightly to keep interior dry, and free of mold, mildew, and odors.

Make sure to read all literature provided with appliances you may have, and follow the maintenance instructions included. Pay particular attention to any cautions or warnings included. Also read the rest of this manual, following the instructions for the care and use of appliances.

Cushions - Fabrics are durable and stain resistant. Always use a foam-type upholstery cleaner for general cleaning and removing of stains. Fabrics can be protected further by treating at least once a year with a fabric conditioner such as "Scotchgard".

Curtains - For best results, all curtains and drapes should be professionally dry cleaned. You can help avoid accumulations of dirt between cleanings by vacuuming, or lightly brushing.

Vinyl Floor Covering - Damp mop with water and detergent. Rinse with clean water and let dry. Avoid using abrasive cleaners.

Wood Surfaces and Pre-Finished Panels - Treat cabinetry and wood surfaces as you would any fine furniture product in your home. Proper care and maintenance of wood products will keep them looking like new for many seasons of use. Clean pre-finished panels with a spray-type furniture polish. Avoid getting wood surfaces wet (wipe off and dry immediately if you do get wet).

Do not use abrasive cleansers around wood finishes. Clean regularly with a soft cloth and cleaner designed for wood products such as lemon oil or any oil based wood cleaning product. Avoid

constant exposure to direct sunlight which can cause fading and drying of wood surfaces. If wood surfaces become stained, sand & refinish as required.

The wood products in your camping trailer can be kept looking like new for the life of the unit with proper care and precaution.

Water System - Check all hoses, fittings, and connections regularly for leaks and signs of wear. Make sure to keep the system sanitized, and take care to winterize during cold weather. Do not allow water to remain in system for extended periods or after a trip.

NOTE: *The fresh water inlet line between the fresh water tank and the galley faucet is protected by a screen filter. The screen is located at the tank where the fresh water access line attaches to the tank. This screen should be removed and cleaned at least once a year, or whenever water flow through the galley faucet seems restricted. If debris has clogged the inlet filter, be sure to also clean the fresh water tank per the instructions outlined in this manual.*

Electrical System - The electrical system requires minimal maintenance under normal circumstances. If you experience electrical problems with your camping trailer, make sure to have it checked by a qualified electrician.

Bed Slides - Lubricate regularly with silicone to insure easy operation.

Roof Vent - Check roof vent regularly for debris that may block air flow or jam cranking mechanism. Lubricate the mechanism with light oil.

ABS Plastic - Some components of the camping trailer are constructed of strong, lightweight ABS plastic. Sometimes, it may be necessary to remove stains, or generally clean. A mild solution of soap and water will clean many stains, and should be used initially. Tougher stains may require stronger cleaners, but be sure to read the label to determine if the product is recommended for use on plastics.

Avoid abrasive cleansers (even liquid and cream types), alcohol based products, and solvents such as acetone and MEK. Gasoline and kerosene should not be used because of damaging effect they have on plastic surfaces, as well as the fire hazard presented. Damage caused by solvents, alcohol, and oil based products may not be immediately noticeable, but the plastic is made weaker, and prone to stress cracking.

WINTERTIME USE

Camping in the winter can be a fun and unique experience, but along with the colder temperatures come new situations to consider.

Water System - The dinette storage lid can be left open to allow warmer air to circulate around the water tank. If this is not practical or possible, given the conditions, an easier solution may be to take water along in plastic containers to store in the heated interior.

Food Storage - Canned goods and other foods packed in water should be stored as high as possible, since heat rises. They might also be stored in the ice box or refrigerator as insulation against the cold. Store dry foods, and other items that are not damaged by freezing in the lower storage areas.

LP Gas System - Make sure to use an LP gas that will vaporize properly in the colder temperatures. Check with your LP gas representative for the proper fuel, and re-read the information on LP gas selection in the Systems section.

NOTE: *It is important to remember that heating with LP consumes gas rapidly, so refill tanks immediately to avoid running out completely.*

Heating - Use Only the furnace to heat the camper. It is properly vented to the outside. *Never use the range for heating - asphyxiation could result.*

Condensation - Cooking produces large amounts of moisture. Not just as steam from pots and pans, but also as a product of combustion. Make sure to open roof vents or unzip a window a little.

WINTER STORAGE

When storing the camper for the winter, certain precautions need to be made to protect it until you open it again for use. Clean the camper interior and exterior as previously outlined, including the ice box or refrigerator. Make sure to talk with your local dealer concerning any special requirements for storage in your particular geographic area.

1. Make sure to park the camper on a level surface.
2. Clean the camper thoroughly, both inside and out, as previously outlined, including the refrigerator.
3. Make sure electrical switches and appliances are turned off.
4. Do not leave a battery in the camper for the winter. It will discharge in 30 to 45 days, and could freeze if not fully charged.
5. Make sure all doors and vents are closed securely. Cover exterior vents on appliances to prevent moisture and insects from entering during storage.
6. Check the interior of the camper periodically while in storage to make sure leaks have not developed that can cause damage to interior components.
7. Make sure the tires are inflated to correct pressures.
8. If snow accumulates on the camper, try to remove it as often as you can.
9. Drain the water system as outlined previously. Remove water from the sink trap, and take the in-line check valve(s) out of the camper and store inside, to prevent the case from cracking as a result of internal moisture condensation. Talk to your dealer before using any type of water system anti-freeze in your camper. Make sure that it is non-toxic, and care is taken in the spring to completely flush and sanitize the water system.

Be sure to read the rest of this manual, and follow any additional information on storage, cleaning, and winterizing procedures.

It is best to store your camper inside if possible, but if it is stored outside, make sure to check and seal all roof joints and seals before storing, and again in the spring.

SAFE OPERATING PRACTICES

Now that you have your new **FOREST RIVER** camping trailer, you're probably anxious to go on your first camping trip. Before doing this however, take some time to become familiar with safe operating habits and practices. A few minutes of time spent before a trip can help prevent accidents during a trip.

Throughout this manual, you will find both notes and warnings. Notes are to highlight information that will make owning and using

your camper easier and more enjoyable, while warnings are given to help prevent you from making a mistake which could cause vehicle damage or possibly personal injury. Pay close attention to both notes and warnings as you read this manual. Although various warnings and safety precautions are mentioned in detail throughout this manual, **FOREST RIVER** feels that it would be helpful to list several of them here, before reading the rest of this manual, to emphasize their importance.

The following recommendations for safe and efficient operation are presented for the purpose of helping you reduce the possibility of personal injury. You as the owner of this camping trailer are urged to read these recommendations carefully. However it is impossible to foresee and describe all such conditions, and it must remain the responsibility of you the owner to anticipate and avoid any unsafe conditions not described below and elsewhere in this manual.

- Think safety. Follow a definite plan for inspection and safe use. Correct unsafe conditions immediately. Always put safety first.
- Never tamper with safety devices.
- Always keep your fire extinguisher on hand and know how to use it. Check regularly to be sure it is in working order.
- LP connections should be checked regularly, and the system should be checked annually by qualified personnel.
- Never overload or improperly load the camping trailer.
- When traveling, make sure all items stored inside and outside the camper are secure, and all doors and drawers are secure.
- Be a good housekeeper... keep surfaces clean and free of hazards. Use only non-flammable solutions for cleaning.
- Plan ahead on what to do in case of fire, have periodic fire drills with your family.
- Check your tires often for condition and proper inflation. Also check the tightness of the lug bolts.
- Guard against contaminated water. Sanitize your system periodically.
- Read and follow all precautions and notes given on labels throughout your camper. Labels that are lost or stolen should be replaced.
- Always be aware of electrical hazards and misuse.
- Always keep a first-aid kit in your camper.
- Make sure to observe all safe rules of driving associated with towing a trailer.
- Read your owner's manual thoroughly!

RULES FOR TRAILER TOWING

- If this is your first experience with towing a trailer, make sure to drive slowly and cautiously while you learn the handling characteristics of your trailer and tow vehicle combination. Also, never allow anyone else who is inexperienced at trailer towing to drive without your direct supervision.
- Always drive within the posted speed limit. Use a moderate speed if driving in traffic or in gusty wind conditions. As your speed increases, your ability to control the trailer/tow vehicle combination is greatly reduced.
- Check bridge load limits; making sure they will support weight of tow vehicle & trailer. Be sure there is clearance for tail swing.
- Never back up until you're sure everyone is clear. If needed, have someone help guide. Make sure this person is always in view and is at a safe distance from the camper.
- Always allow yourself some extra distance to pass or stop. It is recommended to keep at least twice your normal stopping

PERIODIC MAINTENANCE CHART

ITEM	Each Trip	Each Month	3 Mo.	6 Mo.	Yearly	* As Req.	PROCEDURE
Fiberglass Exterior		X			X X		Wash with warm water & mild detergent Wax with liquid or paste wax Check condition of body moldings & reseal as needed
Tent Material	X					X X	Clean, rinse thoroughly with water, & allow to dry Remove stains from vinyl with auto vinyl top cleaner Seal leaks in tent vinyl as required
Roof & Roof Components				X	X		Inspect & reseal as needed Lubricate roof vent mechanism w/light oil and clean completely
Windows & Doors			X		X	X	Clean tent windows w/plastic polish used for auto convertible top windows Lubricate door hinges & step components with WD40 Lubricate door locks & strike pocket, incl. exterior storage & access doors
Seals & Adhesives		X					Inspect and reseal as necessary
LP Gas System						X	Check for leaks & road damage
Water & Drainage				X	X	X	Check hoses, fittings, and connections for leaks and signs of wear Sanitize system (Also check fresh water tank inlet line screen) Winterize system if needed, depending on local seasonal conditions
Electrical						X X	Perform maintenance procedures on converter as outlined in converter manual Check & service battery (if so equipped)
Appliances	X	X					Remove food and ice from icebox or refrigerator after each trip Check for obstructions & dirt accumulations on exterior appliance vents
Safety Equipment		X					Check fire extinguisher pressure and condition
Wood Surfaces		X					Clean pre-finished panels & wood
Weight & Distribution	X						Make sure unit is within specified load limits & that weight distribution is proper
Lifter System				X			Lubricate
Bunks						X	Lubricate bunk slides with silicone
Axles				X			Mounting bolts should be torqued to specific foot pounds
Wheel Bearings				X		X	Repack wheel bearings
Brakes			X			X	Check operation and (or uneven wear)

* As conditions and use warrant (follow instructions outlined in this manual)

distance when towing a trailer, because of the increased weight and length.

- Help to maintain trailer stability by reducing speed when driving downhill, in windy conditions or when cornering. Frequent braking also reduces stability. The weight of the trailer puts additional load on brakes, and can cause them to overheat or fade. Use tow vehicle transmission to help control speed and braking action of trailer and tow vehicle (check tow vehicle manual).

SAFETY REGULATIONS FOR LP GAS SYSTEMS AND APPLIANCES

The following warnings are posted throughout your camping trailer to provide information on LP gas safety. They have been installed not only because of the requirement to do so, but also as a constant reminder to users of the camper to exercise proper caution when using or being around LP gas appliances and equipment. We are listing them here so that you may study them and make sure that you and your family understand and follow them.

1. **⚠ WARNING:** LP GAS CONTAINERS SHALL NOT BE PLACED OR STORED INSIDE THE VEHICLE. LP GAS CONTAINERS ARE EQUIPPED WITH SAFETY DEVICES WHICH RELIEVE EXCESSIVE PRESSURE BY DISCHARGING GAS TO THE ATMOSPHERE.
2. **⚠ WARNING:** IT IS NOT SAFE TO USE COOKING APPLIANCES FOR COMFORT HEATING. COOKING APPLIANCES NEED FRESH AIR FOR SAFE OPERATION:
 1. OPEN OVERHEAD VENT OR TURN ON EXHAUST FAN, AND. . .
 2. OPEN WINDOW

This warning label has been located in the cooking area to remind you to provide an adequate supply of fresh air for combustion. Unlike homes, the amount of oxygen supply is limited due to the size of the recreational vehicle, and proper ventilation when using the cooking appliance(s) will avoid dangers of asphyxiation. It is especially important that cooking appliances not be used for comfort heating as **THE DANGER OF ASPHYXIATION IS GREATER WHEN THE APPLIANCE IS USED FOR LONG PERIODS OF TIME.**

3. **⚠ WARNING:** DO NOT STORE LP GAS CONTAINERS, GASOLINE, OR OTHER FLAMMABLE LIQUIDS INSIDE THE VEHICLE BECAUSE A FIRE OR EXPLOSION MAY RESULT.
4. A warning label has been located near the LP gas container. This label reads: **DO NOT FILL CONTAINER(S) TO MORE THAN 80 PERCENT OF CAPACITY.**

Overfilling the LP gas container can result in uncontrolled gas flow which can cause fire or explosion. A properly filled container will contain approximately 80 percent of its volume as liquid LP gas.

An 80 percent automatic shut-off has been installed on the LP gas tank which will automatically prevent further filling when the gas volume has reached 80 percent of tank capacity.

5. The following label has been placed in the vehicle near the range area:

IF YOU SMELL GAS

- Extinguish any open flames, pilot lights and all smoking materials.
 - **DO NOT** touch any electrical switches.
 - Shut off the gas supply at the tank valve(s) or gas supply connection.
 - Open doors and other ventilating openings.
 - Leave the area until the odor clears.
 - Have the system checked and leakage source corrected before using again.
6. LP gas regulators must always be installed with the diaphragm vent facing downward. Regulators that are not in compartments have been equipped with a protective cover. Make sure that regulator vent faces downward and the cover is kept in place to minimize vent blockage which could result in excessive gas pressure causing fire or explosion.
 7. **⚠ WARNING:** Portable fuel burning equipment including wood or charcoal burning grills and stoves shall not be used inside the vehicle because they may cause fire or asphyxiation.

NOTE: FOREST RIVER is not responsible for any damage to property or personal injury that results from an improperly maintained LP system or appliance.

FIRE SAFETY

Fire safety is an important part of owning a camping trailer. The following basic rules of fire prevention can help eliminate the possibility of a fire.

1. Never store flammable liquids in the camper.
2. Never leave cooking food unattended.
3. Never smoke in bed, and always use an ashtray.
4. Never allow children to play with LP gas or electrical equipment.
5. Never use an open flame as a flashlight.
6. Always repair faulty or damaged wiring and electrical components.
7. Never overload the electrical circuit.
8. Locate and repair LP leaks immediately.
9. Keep cooking surfaces clean.
10. Don't allow rubbish accumulation.
11. Never clean with flammable liquids.
12. Spray fabrics annually with a flame retardant.
13. Make sure curtains near the range are held back with the elastic curtain straps provided in the curtain packets when the range is lit.

If a fire does start, make sure to follow basic rules of safety:

1. Have everyone evacuate the camper as quickly as possible.
2. After everyone is clear, check the fire to see if you can attempt to put it out. If it is large, or the fire is fuel-fed, get clear of the camper, and have the fire department handle the emergency.

- DO NOT** attempt to use water to put out the fire. Water can spread some types of fire, and electrocution is possible with an electrical fire.

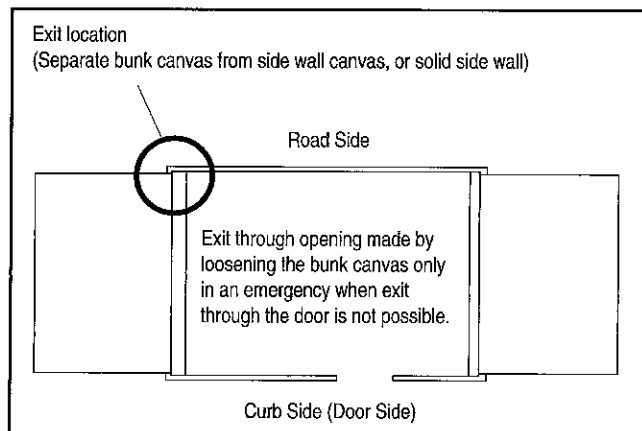

Camper Emergency Exit Location

FIRE EXTINGUISHER

If you determine that you can attempt to control the fire using the fire extinguisher, make sure you know how to use it. Read the label on the fire extinguisher, and study the information outlined here to become familiar with safe operation and maintenance of extinguisher.

The fire extinguisher provided with the camper is a chemical type suitable for extinguishing small fires of the class B or C type.

Underwriter Laboratories classify fires into three types:

- Class A - Fires in wood, paper, fabric, rubber, & certain plastics.
- Class B - Flammable liquids such as grease, cooking oils, gasoline, or kerosene.
- Class C - Electrical fires started from live electrical wires from short circuited motors or switches.

Extinguishers are designed to put out a fire in the initial stage, not when it is blazing out of control. If a fire cannot be approached within ten feet, it is probably too late to do any good.

To fight a fire with an extinguisher, first remove the tamper tape which covers the discharge push button. The extinguisher does not need shaking. Hold it upright and stand six to ten feet from the fire with a clear path to an exit. Press the button down all the way, aimed at the base of the fire and spray with quick motions from side to side.

Avoid inhaling the dry chemicals. Although non-toxic, they could cause temporary irritation and vomiting. When the fire is out, clean up area as soon as possible. The dry chemicals are non-corrosive, but some residue may cause surface damage if left too long.

In the case of an electrical fire, disconnect the electrical supply on the outside of the camper.

To keep a fire extinguisher in operating condition:

- Check pressure** - monthly or more often. Check the nozzle for obstruction. Press the green pin below the nozzle. If it returns and sticks out from the extinguisher, it is operable. If the pin does not come back, discard the extinguisher. On refillable models, there is a pressure gauge to check.
- Tamper tape** - Check the tape to make sure it is intact. **DO NOT** test the extinguisher. Even a partial discharge may cause leakage, and make it useless when needed.

- Inspection tag** - When checking the extinguisher for pressure, enter the date checked on the inspection tag furnished with the trailer. Regular inspections will help insure the extinguisher is in operating condition.

LOAD LIMITS & WEIGHT DISTRIBUTION

Your camper has been designed to carry loads within specified limits. Exceeding these limits will greatly effect handling, safety, and can cause damage to camper components. Load limit and weight distribution terminology is as follows:

- Gross Vehicle Weight Rating (GVWR)** - This is the total designed weight rating of the camping trailer. It includes everything that combines to give the camper its total weight when traveling. Included are the weight of the camper, all appliances and conveniences, water, LP fuel, and all personal belongings and gear stored both inside and outside. This value must never be exceeded.
- Gross Vehicle Weight (GVW)** - This is the total loaded weight of the camper, under any given load condition, up to a maximum of the GVWR.
- Tongue Weight** - This is the weight of the tongue as it bears down on the hitch of the towing vehicle. Tongue weight should be determined with the camper as it would be fully loaded for travel. For stable towing at highway speeds, this weight must be a minimum of 10% and a maximum of 15% of the gross vehicle weight.
- Gross Axle Weight Rating (GAWR)** This is the designed weight rating of camper axle when hitched to towing vehicle.
- Gross Axle Weight (GAW)** - This is the total loaded axle weight under any circumstance, up to a maximum of GAWR. Since a side to side load imbalance can occur, each side should be weighed separately also. The weight supported by each side must not exceed GAWR divided by two.
- Shipping Weight**- This is the weight of the vehicle with standard equipment.
- Unloaded Vehicle Weight (UVW)** -This is the weight of the camper as equipped with options. For our purpose, the unloaded vehicle weight is the weight of the unit with maximum options.

▲ WARNING: Exceeding the weight ratings of the camper can create a serious safety hazard. Check the weight of your camper frequently as it would be loaded for travel. Remember to take the weight of all liquids into consideration. Also, make sure that the weight is distributed evenly.

The weight ratings of your camper are listed on the weight certification decal located on the roadside of the camper, near the front corner.

Cargo capacity is the difference between a camper which is unloaded, and the GVWR. When establishing cargo capacity, weigh with the camper as empty as possible, including the water tank. **DO NOT** assume that you can fill all tanks and storage areas and be within the GVWR. Weights of stored items will vary greatly and affect the total weight of your camper.

Always give careful consideration when loading your camper so that items will be evenly distributed. It is also important to keep in mind while traveling, that all items stored inside and outside the

camper are secure, and all doors and drawers are secure. **DO NOT** add any type of rack or frame to the body or frame. The alteration to length and/or weight distribution may result in unstable handling, be a safety hazard, or could damage camper components. In any case, the camping trailer warranty may be effected.

Always weigh the camping trailer at a certified weigh station equipped with platform scales. Check the telephone directory or with local authorities for the location of weigh stations in your area. Weigh your camper with all equipment, luggage, and fluids on board that you plan to take along. You will need to weigh the unit periodically to assure that you are maintaining correct balance.

To weigh your camper properly, use following procedure:

1. Level the camper and make sure that it remains level throughout the weighing procedure.
2. For gross vehicle weight, pull the camper onto the scales and weigh with both the axle and front jack resting on the scale. The difference between the weight of the camper fully loaded and empty is the rated personal cargo weight. If for example the GVWR of your camper is listed at 3000 lbs. and it weighs empty at 2200 lbs. your personal cargo weight cannot exceed 800 lbs. The GVW must not exceed the GVWR found on the certification decal.
3. For tongue weight, rest only the hitch on the scale and weigh with the camper fully loaded for travel. Check the weight against the proper tongue weight as listed on the certification decal. The tongue weight must be between 10% and 15% of the GVW for best towing. However, follow the weight recommendations given by the hitch and tow vehicle manufacturers. It may be necessary to reposition your load to obtain correct balance.
4. For gross axle weight, pull forward so that only the camper axle is setting on the scale. If the weight exceeds the GAWR on the weight distribution information sticker, remove or redistribute the weight in the camper to meet the proper specification. The difference between gross vehicle weight and gross axle weight is the tongue weight.

NOTE: Gross axle weight is determined with both tires on the scale, but side to side weight distribution has to be determined by weighing each side separately. The values obtained by weighing each side separately must not exceed the GAWR divided by 2.

Compare scale weights with capacities as shown in the following example.

GROSS VEHICLE WEIGHT RATING	2200 lbs.	
GROSS VEHICLE WEIGHT	<u>1980 lbs.</u>	From Scale
RESERVE CAPACITY	220 lbs.	
GROSS VEHICLE WEIGHT	1980 lbs.	From Scale
GROSS AXLE WEIGHT	<u>1765 lbs.</u>	From Scale
TONGUE WEIGHT	215 lbs.	

CHECK: GVW multiplied by (.10) = 198 lbs. by (.15) = 297. Compare the range of 198 lbs. to 297 lbs. to the actual tongue weight of 215 lbs. to make sure it is within proper limits. Gross Axle Weight Rating (GAWR) = 2200 lbs.

Left Tire 875 lbs. (Scale Weight)
Right Tire 890 lbs. (Scale Weight)

Compare actual weights for right and left tires to GAWR (2200 divided by 2 equals 1100 lbs.) Side to side balance should be as equal as possible. A maximum of 25 lbs. difference is acceptable. The GVWR, GAWR, and the recommended 10% to 15% tongue weight must not be exceeded under any circumstances.

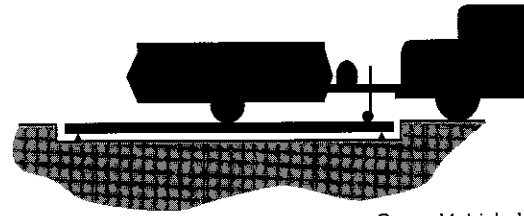

Gross Vehicle Weight

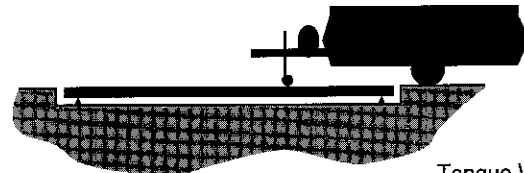

Tongue Weight

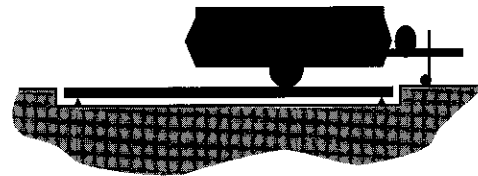

Gross Axle Weight

If additional items must be added to the unit after it has been weighed and the loading analysis completed, the following method may be used to prevent overloading:

1. Weigh each additional item using a bathroom scale before placing them in the camper. The total of these items are then added to the GVW originally determined.
2. The tongue weight must then be re-calculated using the new GVW as shown in the sample calculation.
3. The bathroom scale can be placed under the jack with the camper level, and the tongue weight read directly from the scale. The scale reading must fall within the bounds determined previously. The tongue weight can be increased by moving cargo forward, and decreased by moving cargo rearward. However, too much weight in the rear can cause trailer sway or handling instability.

Once you become familiar with loading your camping trailer and know how to distribute the weight and which items you normally carry, make a list and diagram you can use for future reference. Plan your loading and storage so that emergency items are easily accessed. Place heavier or breakable items on the camper floor for greater load stability. Make sure these items are well packed and secured to prevent movement. Take extra care not to overload the front and rear ends of the camper.

Make sure to use packing material around breakable items such as plates and glasses in cupboards if you will be towing over rough roads or terrain. It is a good idea to use non-skid materials under heavier items to help prevent shifting.

Most new camping trailer owners tend to carry more supplies than they really need. It is important to remember that each item added brings with it the extra weight to tow and distribute.

⚠ WARNING: DO NOT store LP gas containers, gasoline, or other flammable liquids inside the camper because a fire or explosion may result.

TOWING VEHICLE REQUIREMENTS

When considering a towing vehicle, keep in mind certain requirements for safe and easy use:

- **Transmission** - The transmission can be manual or automatic, but for most people, an automatic transmission will control engine loads better.
- **Power** - Make sure your towing vehicle has adequate power to tow your camper on the type of roads you will be using. Factors to consider are engine power, cooling capabilities, and axle ratio. Discuss the towing capabilities of your vehicle with your **FOREST RIVER** dealer and tow vehicle dealer.
- **Hitch** - Make sure that your vehicle can have a Class II weight carrying hitch installed, and that it is installed properly (**DO NOT** use a weight distributing hitch under any circumstances).
- **Safety Equipment** - Make sure to install proper safety equipment such as towing mirrors. Most styles available are not permanent and can be easily installed. Check with your dealer for correct types and methods of installation. Also install proper hitch wiring to supply 12 volt power to camper for turn signal and brake light operations.

HITCH

To safely tow your new camping trailer, you will need to install a class II weight carrying hitch with a 2" ball. It is very important to choose a hitch designed for attachment to your particular tow vehicle, and have it properly installed. Pay particular attention to tongue load limits of your tow vehicle and hitch that you purchase.

⚠ WARNING: Make sure to choose a hitch that does not overload the axle on the tow vehicle. Also make sure that the hitch mounting is not below or more than three inches above leveled camper tongue.

⚠ WARNING: DO NOT use a weight distributing hitch under any circumstances. Failure to heed this warning will result in frame damage, tire and brake failure, and will void your FOREST RIVER warranty.

WIRING

Along with your hitch, it is also necessary to install proper electrical connection from the tow vehicle to your camper. A car end pigtail is supplied with leads of adequate length to allow connection to your tow vehicle wiring system. Make sure that you use wiring of the correct gauge with sufficient slack between the camper and tow vehicle to allow for turning without dragging on the ground. Have your tow vehicle dealer, and/or hitch installer assist you with the installation.

NOTE: If your tow vehicle has a separate amber turn signal, it will require a special adapter to allow your trailer lights to function properly. This adapter may be purchased from your dealer.

The wiring color code for connection is as follows:

- White - Ground.
- Green - Tail, clearance identification, and side marker lights.
- Red - Left turn and stop.
- Brown - Right turn and stop.
- Blue - Optional electric brakes.
- Black - Interior lights and accessory (connect directly to the tow vehicle battery using #14 wire and a 15 amp in-line fuse at the battery. Be certain the wire is properly routed away from the exhaust system and moving parts).

Although your camping trailer has been checked at the factory, we recommend that you visually check to see that all lights are functioning properly before leaving your dealer.

HITCHING

When attaching the camper trailer coupler to the tow vehicle hitch, use the following steps:

1. Raise the coupler by cranking the jack handle clockwise.
2. Back the tow vehicle up until the ball on the hitch is as nearly under the coupler as possible. Have someone assist you in this with the use of pre-determined hand signals. Make sure this person is in view at all times and proceed slowly and cautiously.
3. Lift the coupler latching lever.
4. Lower the coupler onto the hitch ball by cranking the jack handle counterclockwise. Allow the coupler to properly settle onto the hitch ball.
5. Close the coupler latching lever, making sure that it is fully locked in place.
6. Raise the jack post as high as needed by cranking counterclockwise.
7. Fold the cranking handle down against the jack post.

SAFETY CHAINS

After you have the camper coupler properly attached to the hitch ball, the safety chains must be attached.

To do so proceed as follows:

1. Cross the safety chains under the tongue and hitch.
2. Attach the hooks to the chain attachment loops provided on the tow bar portion of the hitch or to the vehicle frame.
3. Make sure that the chain slack length is equal on both sides and that it is sufficient to allow the vehicles to turn at their minimum radius without the chains dragging on the pavement.

⚠ WARNING: Do not attach the safety chains to the vehicle bumper.

NOTE: Safety regulations require the safety chain to be crossed under the tongue and hitch to prevent the tongue from dropping to the ground in the event of a hitch or coupling failure.

Do not attempt to repair a damaged chain. If the safety chain has been damaged, it must be replaced.

ELECTRICAL HOOK-UP

Plug the towing vehicle electrical pigtail into the socket located on the camper frame. Be sure to allow enough slack to prevent disconnection during short turns. Check all lights for proper operation before pulling away.

BRAKES

Your electric brakes (optional on some models) are wired to the towing vehicle through the electrical pigtail. When attached, they distribute even braking power to both the towing vehicle and the travel trailer.

Talk to your dealer about the types of brake controllers available, and proper installation of the controller on your towing vehicle. Have him explain electric brake operation, and their proper use, as well as the importance of the load resistor and safety break-away switch.

Make sure to test the brakes and adjust them as necessary, per the instructions of the brake controller manufacturer. Proper adjustment of the brakes can help to avoid dangerous swaying or jack-knifing on slippery pavement, or during an emergency stop.

Before taking your folding camping trailer on a trip, check for proper brake action on a short road test. Apply the brakes several times at different speeds and pressure. If wheel lock-up occurs, the brake shoe adjustment is too tight. If no trailer brake action is occurring, brake shoe adjustment is too loose. Do not exceed a speed of 30 mph during this road test. Refer to the Brake/Axle Owner's Manual for adjustment procedures and troubleshooting guide.

⚠ WARNING: *Make sure the safety brake-away lever is in the released position before towing the camper.*

DRIVING AND TOWING TIPS

Now that you are familiar with load limits and weight distribution, as well as hitching up your camping trailer to the towing vehicle, take some time to go over these driving and towing tips that will make trips with your camper both safer and more enjoyable.

- When first learning about towing your new camper, it is wise to find a spot that affords space to practice accelerating, turning, braking, and backing before actually taking the camper on a trip.
- A set of trailer mirrors on your towing vehicle increase visibility, and are required by law in many states. Most styles are not permanent, and can be easily installed. Keep the mirrors adjusted properly and check them often.
- Before leaving on a trip, inspect your hitch, brakes and tires. Make sure everything is connected properly and working.
- Always remember that the camper wheels do not track exactly in the same place as the tow vehicle wheels. Because of this, make sure when turning to pull ahead a sufficient extra distance to allow for the additional tail swing required for the camper.
- Remember that the additional weight of the camping trailer affects acceleration and braking distances. Accelerate slowly and smoothly. When pulling into traffic, make sure there is enough distance to merge safely. Keep a safe distance between yourself and the traffic ahead. Apply the brakes with

enough time to slow or stop safely. The heavier your camper, the greater the distance required to bring it to a stop. A panic stop can cause the camper to jack-knife, which can result in damage to your vehicles, or cause an accident.

- Always drive within the speed limit. Reduce speed if you encounter gusty winds, heavy traffic, or unusual road conditions.
- Never back up until you are sure it is clear. Use your mirrors to check for obstructions. If needed, have someone help guide you. Make sure this person is always in view and at a safe distance from the camper.
- Avoid sudden movements when changing lanes. Always check your mirrors and signal your intention before passing.
- When driving on steep grades, select the correct transmission range, and drive at proper speeds. Downshifting will allow the engine to help control your speed and relieve the extra strain on your brakes. Continuous application of the brakes can cause them to overheat, and could result in a temporary loss of braking. Never exceed the appropriate speed when driving in a lower gear. Excessive speed in a lower gear can overheat the tow vehicle transmission, which can lead to transmission failure.
- If you encounter driving conditions that put additional strain on the engine, it may be necessary to turn off the tow vehicle air conditioning to improve engine cooling.
- Don't drive with your foot resting on the brake pedal. Abnormally high brake temperatures and lining wear will result, increasing stopping distances.
- If your tow vehicle is equipped with cruise control, don't use it on wet or icy roads, in congested traffic, or on winding roads.
- Sometimes when a large truck or a bus passes you, the air from the vehicle may push the rear of the camper to the right, and then affect the front. You may compensate for this additional trailer sway by steering for a moment, very slightly toward the passing vehicle.
- If the camper should ever disconnect from the tow vehicle while driving, slow down and come to a controlled stop at the side of the road. The safety chains will keep the camper attached to your towing vehicle.

BACKING UP

Backing up with an attached trailer brings with it a new set of driving rules for many first time camper owners. When backing up, it is important to proceed slowly. If the camper turns the wrong way, stop and take a moment to consider how to correct the error. The following pointers should help you with your initial attempts at backing.

- Always concentrate on the back of the camper.
- When your tow vehicle and camper are in a straight line, hold the bottom of the steering wheel, and turn it in the direction you want the camper to go.
- Try whenever possible, to back up to the left, because you will be able to see the action of the camper easier.
- If you don't achieve the desired result on the first try, pull forward and try again, rather than trying to correct in a tighter space.
- Use your mirrors, making sure vision is not obstructed.
- When the camper is proceeding in the direction you want it to go, allow the tow vehicle to "follow". Turn the steering wheel sharply to bring the camper and tow vehicle back to a straight line. When you have both vehicles in a straight line, straighten the front wheels of the tow vehicle before proceeding.

1. Turning the wheel as shown and backing up will bring you to position B.
2. Turn the wheel in opposite direction and back up to position C.
3. Straighten the vehicles by turning the wheel as shown and backing up.

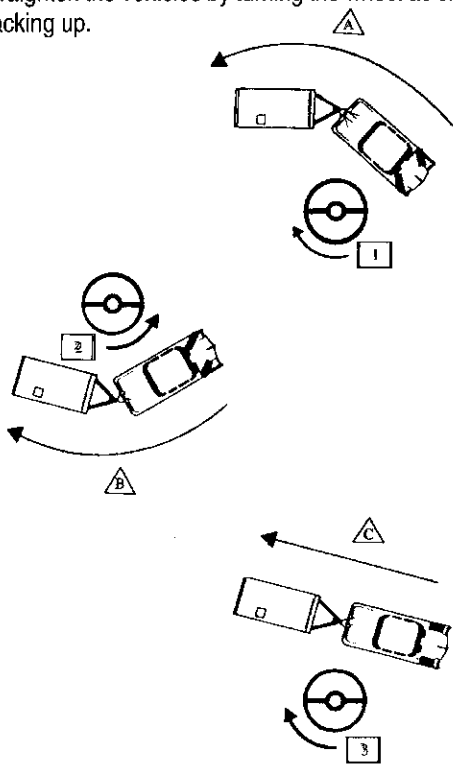

Backing Procedures

Practice is the best method in becoming proficient at handling your camper in all situations. Taking the time needed initially to be comfortable when towing it, can pay the dividends of a safe and enjoyable trip.

TIRES

Your camper tires play an important role in the load carrying capacity of the vehicle. To ensure good tire life, check your tires often. Inspect the general condition of the tire, as well as the air pressure.

Always check the air pressure when the tire is cold. Tires that are hot from traveling will show higher pressures. The correct tire pressure and the load carrying capacity of the tire is imprinted on the side of each tire sidewall. Remember that the air pressure in your camper tires will not be the same as the pressure in your towing vehicle tires. Always inflate camper tires to their correct pressure. Do not over or under inflate. Under inflated tires will run hot, shorten the tire's life, and decrease the camper's safe load limit, while over inflated tires will cause a rough and bouncing ride that can damage camper components or cargo.

NOTE: Cold tire inflation pressure is defined as a tire that has not been used for 3 or more hours, or has been driven less than 1 mile. Tire inflation pressure of a hot tire may show an increase of as much as 6 psi over a cold tire.

If you notice damage to a tire such as a bulge, uneven wear, or damage by a foreign object or the road, have it inspected and repaired or replaced as warranted. Remember that tires should be taken to an authorized tire repair facility.

When replacing a camper tire, make sure to replace with a tire of the same size and specifications.

LUG NUTS

▲ It is also important to check the wheel lug bolts regularly for tightness. Each lug bolt should be torqued to 90 - 95 lbs. Check the lug bolts per the following schedule:

1. After the initial test, check again after the first 50 miles.
2. Recheck every 50 miles for the next 200 miles.
3. Thereafter, check before each trip.

Make sure to check the lug bolts following periods of excessive braking. Make sure that the lug bolts are seated in the counter-sunk holes of the wheel, and keep them free of rust. Refer to the axle manufacturer's operation and maintenance manual for additional information concerning the camper's wheels and lug bolts.

CHANGING A TIRE

When it is necessary to change a flat tire while traveling, the first consideration is safety. Use the following steps when changing a tire:

1. If the flat occurs while driving, bring your tow vehicle and camper to a controlled and gradual stop.
2. Pull off the road as far as safely possible.
3. Turn on hazard warning flashers.
4. If the flat occurs at night, use flares or warning lights also.
5. Use a block to stabilize the opposite wheel.
6. If the wheel has a hub cap, remove it.
7. Raise the camper slightly with a hydraulic or scissors style jack placed directly under the camper frame. Do not use a bumper style jack, or place any jack under the bumper.
8. Loosen the wheel lug bolts.
9. Use the jack to raise the tire off the road.
10. Remove the lug bolts and keep them together where they will not be lost.
11. Remove the wheel and replace with the spare wheel and tire.
12. Replace the lug bolts and tighten by hand.
13. Lower the wheel to the ground and tighten the lug bolts in the sequence previously outlined. When possible, check to make sure they are tightened to 90-95 ft. lbs. Recheck the torque at 50 miles, and every 50 miles thereafter for the next 200 miles.
14. Replace the hub cap, and store the old tire, the jack, and all tools and safety equipment.

After changing a flat, have it repaired or replaced as soon as possible.

If you find yourself with a flat tire and no spare, and you must leave the camper while you go for a replacement tire or repair of the flat, make sure to solidly stabilize the camper to prevent it from moving or falling off the jack.

A spare tire is an option on all models. All models if equipped with a spare tire, have it mounted on the outside rear wall of the camper.

CAMPSITE SELECTION & SET-UP

When initially familiarizing yourself with your new camping trailer, it is always a good idea to take a short trip first to a local campground. There you can learn about your new camper before you take it on an extended trip.

SET-UP TIPS AND PRECAUTIONS

Before setting up your new camper, always keep the following tips and precautionary guidelines in mind. Make sure to check the index for further instructions on these items.

1. Choose a campsite that is as level as possible from side to side. An uneven campsite can cause binding of the lifting system.
2. Make sure there are no low hanging branches or other obstructions that will interfere with moving the camper into the site, raising the roof, or extending the bunks.
3. Check the placement of campsite electric utility outlets, remembering the length of the camper's power cord.
4. Make sure to release all four roof latches before attempting to raise the roof.
5. Block the camper wheels to prevent movement.
6. Remove all items you may have stored on the roof before attempting to raise it.
7. If your camper is equipped with an awning, make sure it is attached to the camper before raising the roof.
8. **DO NOT** lower the stabilizing jacks until the roof of the camper has been raised.

⚠ WARNING: The stabilizing jacks are for support only, and are not intended as means of leveling the camper. Attempting to use the jacks as leveling tools may result in damage to the lifter system.

SETTING UP THE EXTERIOR

Use the following procedure for initial set-up of your camper.

1. Insert the dolly wheel onto the jackpost and lock it in place
2. Disconnect the safety chains from the tow vehicle, and unplug the electrical connection.
3. Raise the cranking handle on the jack post and lower the dolly wheel to the ground by cranking the handle counter-clockwise. A small plywood block can be used to prevent the wheel from sinking into soft earth.
4. Release the coupler latching lever.
5. Raise the coupler free of the hitch ball with the dolly jack.
6. Move the tow vehicle away from the camper.
7. Level the camper from front to back by raising or lowering the dolly jack as required.
8. Release all four roof latches.
9. Crank the lifting system lever clockwise until the green gauge cable located by the left front corner is tight.

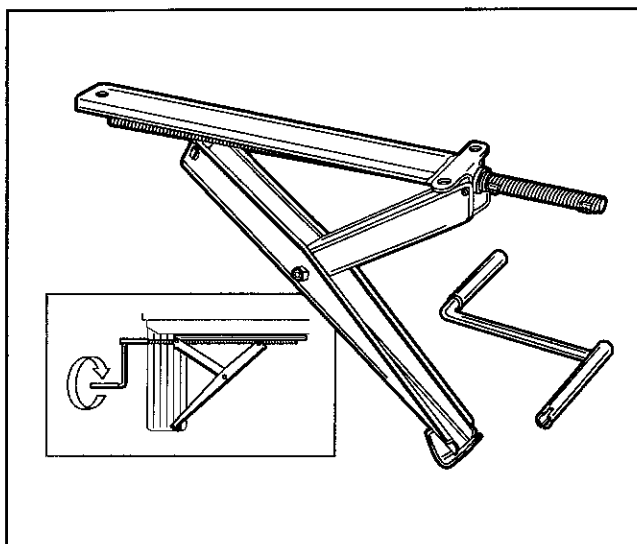
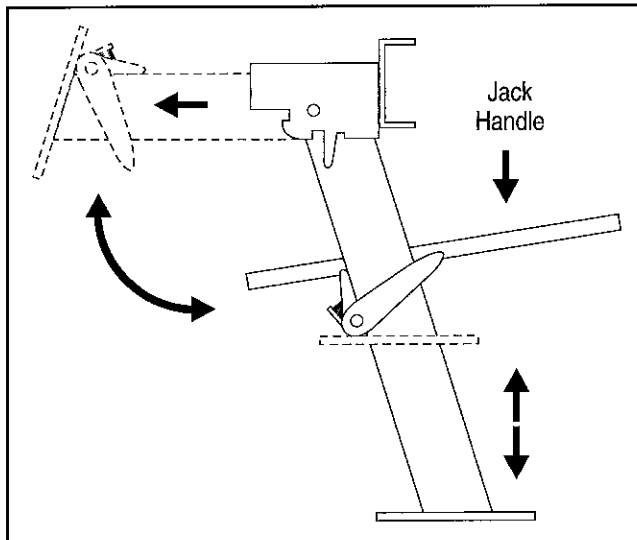

Stabilizing Jacks

⚠ WARNING: DO NOT overcrank the lifting system. Hold the lifting system handle firmly. DO NOT release the handle while there is lifting pressure on it. Lifting pressure can be relieved by reversing the direction of the handle back for one quarter turn. This will help ensure proper clutch engagement to hold the lifters in place. If the lifting pressure is not released in this way, the handle could spin violently, which may cause personal injury.

NOTE: Make sure to replace the handle in the storage compartment to insure that it will not be lost.

10. Lower the stabilizing jacks to the ground so that the camper is well supported. A jack handle is provided that assists both in releasing the jacks, and extending them. Small plywood boards placed under the jacks can help to increase the campers stability when parked on soft ground.

⚠ WARNING: Keep hands/fingers away from pinch points on stabilizing jacks when extending or retracting them.

SETTING UP THE BUNKS

1. Before proceeding, make sure tent is clear of bunk slides, and you have the bunk support poles available (a good place to store the support poles is under the mattress where they can be retrieved when needed). If there appears to be some other interference keeping the bunks from sliding out, DO NOT proceed until the source of interference has been found and corrected.

NOTE: *Be sure to keep bed slides well lubricated. Check the maintenance instructions in this manual.*

2. Pull the bunks out until they reach the bunk stops.

▲ WARNING: *Make sure at this point that no additional weight is placed on the bunks before the bunk support poles can be inserted.*

3. Raise each bunk a few inches while inserting the flattened end of the support poles into the bracket under the bunk, and the tubular end into the frame support sockets. Make sure all the support poles are properly in place.
4. Straighten the tent until it is square with the bunk.
5. Reach under the tent, and rotate the bunk bow support up into position.
6. Pull the tent over the sides of the bunk decks.
7. On campers with sectionalized tents, make sure each of the corners are fastened all the way down.
8. Reach under the bunks and attach tent flaps to velcro on bottom of bunk.
9. Push to snap end of center support rafter into center of the bow support. Push the bunk bow support forward with the center rafter support. When the tent is taut (The support rafter's length can be adjusted by releasing snap button and adjusting to next tighter position. When loosened, slide the two pieces in or out to achieve the length desired), secure the opposite end of the center support rafter into the appropriate metal tab on the ceiling support bracket.
10. Outside, pull the tent corner flaps around the roof support poles, and secure to the velcro strips. This will prevent water from entering the lifter system.

ENTRYWAY SET-UP

To complete the exterior set-up of your camper, the combination screen and storm door will need to be installed.

1. Release the swing down combination door from the roof by turning the two retaining locks.

▲ WARNING: *Keep a firm hold on the door when releasing it, so as not to cause damage or injury.*

2. After swinging the door down, attach to the lower door by inserting the U channel on the bottom of the door over the top of lower door. At the same time, make sure the pegs on both sides of the combination door are inserted down into the camper side wall channels. It may be necessary to raise or lower the rear doorside stabilizing jack slightly to achieve proper entry door fit.

3. Lock the top of the door in place by turning the two retaining locks to a vertical position over the door slots.
4. Unlock the door from it's frame by turning the retaining lock.
5. Fasten the tent side walls to the door by wrapping the end flaps around the outer door frame and attach to velcro strips.
6. Stretch the two corners of tent down and attach to velcro strip. This will prevent water from entering door and side wall channels.

STEPS

Optional steps can be purchased in two styles of permanently attached steps that fold up or down as required.

SETTING UP THE INTERIOR

Once you have the exterior and entryway set-up, interior set-up consists of the following operations:

SLIDING WARDROBE

Some models have a wardrobe that is hinged and attached to the rear or side wall of the camper. When in the storage position, it rests on the floor. To raise the wardrobe to its usable position, proceed as follows:

1. Grasp the wardrobe at the bottom near the floor.
2. Lift the wardrobe, allowing it to rotate up to a vertical position.
3. When upright, slide the wardrobe to the side until it rests fully on the countertop that will support it.

▲ WARNING: *Be sure to keep a firm hold on the wardrobe when raising or lowering it, so it will not slip from your grasp and damage the unit, or cause an injury.*

To lower the wardrobe for travel or storage, reverse the procedure outlined above. Make sure to remove the wardrobe contents, including objects on the utility shelf, before lowering.

FOLDING CLOTHES HANGER

Some models without a wardrobe have a ceiling mounted folding clothes hanger. When needed, release the catch and rotate the bar down for use. Remember to remove hanging clothing from the bar, and fold the bar back to its flush mounted ceiling position before lowering the roof for storage or travel.

HIGH-RISE KITCHEN COUNTER

High-rise kitchen counters are used in **FOREST RIVER** camping trailers. On some models, you will need to grasp the two front corners of the counter and pull up until it locks into place. To lower, lift up on the rear corners to release the locking mechanism, and fold down.

On the other models, the counter is raised into position by grasping the front of the kitchen unit at the floor, and lifting up and rotating over at the same time. Keep a firm hold on the kitchen unit while lowering it down onto the base that will support it. To lower the unit for storage, reverse the procedure by rotating forward and down to the stored position on the floor.

FLIP-UP COUNTERTOP EXTENSION

Some models include a flip-up countertop extension on the front of the high-rise kitchen counter. When raised and locked in position, it adds additional countertop space for kitchen activities. To use, raise the extension up to a level position and lock the support arm in place by pushing up and in on the support arm. Visually check the support arm to make sure it is straight and fully locked. Test the extension by applying some slight pressure on it. To lower, grasp the support brace and give a downward pull to unlock. Lower the extension to its stored position.

The red cable attached to the bottom of the countertop extension is a safety feature designed to keep the complete high-rise kitchen counter unit in place if a heavy object is placed on the front of the countertop extension. The additional weight could potentially lift the rear of the kitchen unit, releasing its locking mechanism. Make sure not to allow anyone to sit on, or set heavy items on either of the flip-up countertops.

⚠ WARNING: Make sure to keep hands and fingers away from pinch points on the support brace when raising or lowering the flip-up countertop. Also, don't use the countertop extension to support heavy or dangerous items such as hot food, or boiling water.

PULL-OUT KITCHEN

If your camper is equipped with a pull-out kitchen, the kitchen counter can be located either on the inside or the outside of the camper. To set up on the inside, the procedure is the same as described for raising the high-rise kitchen counter. To set up the kitchen on the outside, open the kitchen access door on the curb side, unlatch the barrel bolt, and simply slide the complete kitchen unit out by pulling with the handle provided. To replace the camper for travel or during inclement weather, push the unit back to its original position. Latch the barrel bolt and close and lock the access door.

INSIDE/OUTSIDE RANGE

On models equipped with the portable inside/outside range, you may use the range setting on the kitchen counter, or it may be attached to the outer sidewall of the camper on the mounting bracket provided. In either case, before the range can be used, you must connect it to the LP gas supply. A quick disconnect fitting on the range is there for this purpose. When connecting the range to the LP gas supply, the LP valve on the disconnect must be in the OFF position (valve handle at a right angle to the gas line). To attach the quick disconnect, hold the gas line, pull back on the outer connecting collar, and insert over the range connection. When connected, turn the gas valve to the ON position (Valve handle in line with the gas line). To attach the range on the outside wall, be sure that the lip on the extrusion across the back of the range fully locks into place into the extrusion mounted on the camper sidewall. DO NOT let go of the range until you are sure that it is securely locked in position. On some models, an additional brace is also required that fits into a slot on the underside of the range and also into a slot mounted on the camper sidewall.

On some models, there is a bracket on the wall inside the camper near the floor that is used to secure the range when it is being stored

for travel. This prevents movement and damage to the range while the camper is being towed.

⚠ WARNING: Always make sure to observe proper LP gas safety rules.

DINETTE

The dinette on some models is set-up in the following manner:

1. Insert the lip on the extrusion across the back of the table into the locking extrusion mounted on the camper wall.
2. Pull the table leg out of the detent notch locking it in place, and rotate it down. When the leg has rotated 90 degrees, the spring detent will engage into the table position detent notch.
3. Adjust the leg for proper height by lifting out on the spring clip and telescoping the leg down. Insert the spring clip into the hole that will secure the leg at the correct height.

Reverse this procedure for removing the table top for travel or storage.

On some models the dinette table top can also be attached to the outside camper side wall in the same way by using the table top locking extrusion provided. When needed, the dinette will convert to an additional bed by removing the table from the wall bracket, folding back the support leg, and allowing the table top to rest on the support strips along the front of each dinette seat. Complete the sleeping provision by arranging the four dinette cushions into a mattress.

The dinette table top on some models, is supported by a pedestal which inserts into brackets both on the floor and the underside of the table top. To convert to a bed, remove pedestal and place it on floor between the dinette seats, rest the table top on the support strips along the front of each dinette seat, and arrange the cushions to form a mattress.

NOTE: Never allow the table to be exposed to excessive moisture, as damage will result.

GAUCHO

The gauchito is a couch-like seating space on some models. It can also be converted to a bed by pulling the gauchito top forward, and using the gauchito cushions to make the mattress.

TAKE DOWN PROCEDURE

Taking down your camper is mostly the reverse process you used to set it up. However, it is important to make sure that various systems and features are shut off and stored properly, as well as making sure that moisture and debris do not damage camper components while it is stored. To take down your camper, proceed as follows:

1. Make sure all windows and curtains are closed or properly tied back as required.
2. Unzip the tent at each corner.
3. Place the dinette and any other table in its stored position, as well as the accompanying cushions.
4. Lower the kitchen unit and the wardrobe as you are equipped, per the instructions as previously outlined.

NOTE: Before lowering the kitchen unit, make sure that all range controls are in the OFF position, the cover is closed, and the LP gas valve is in the closed position. Also, make sure that if you have an inside/outside range, that it is secure in its proper storage position.

5. Close the roof vent. Make sure no debris has lodged under the cap which can damage the screen or the mechanism.
6. Turn off all interior lights, and make sure the converter switch is in the off position.

⚠ WARNING: Failure to turn off ceiling lights and converter can result in damage to unit.

7. Unplug the electric power cord from the outside supply and store.
8. Disconnect water hookups and store the hose.
9. Make sure any LP gas accessory pilot light is out, and the main gas valve has been shut off. If your camper is equipped with a refrigerator, make sure to switch it over to 12 volt operation if there are contents that require it.
10. Unsnap the tent at the door, and remove the tent from around the door frame.
11. Lock the combination storm and screen door to the door frame, lift the entire door off the lower door, and swing it up to its stored position, fastening it to the roof with the two retaining locks.
12. If your camper is equipped with a step, store it as required.
13. Make sure that the interior cabinets, dinette, wardrobe, etc. have been lowered or placed in their travel positions.
14. Zip up all windows, and make sure that curtains will not obstruct or be damaged by the bunk.
15. Release the velcro strips securing the tent corner flaps around the roof support poles.
16. Remove the center support rafter and put it in its storage position on the dinette, under the cushions.
17. On models with two piece hinged bunk supports, remove the bunk locking pins from the bunk slides.
18. Lower the bunk end bows.
19. Remove both lifter safety posts.
20. Release the tent flaps from the velcro under bunks and lift the tent up onto the bunks.
21. Make sure the tent is pushed back and away from the edge of the bunks.
22. Raise each bunk a few inches and remove the support poles from the support sockets. Store the support poles in a convenient location such as under the bunk mattress.
23. Push both bunks into their travel positions. Make sure that tent does not catch or bind when pushing the bunks in.
24. Release the stabilizer jacks, and swing them up into the traveling position.
25. Insert the lifting mechanism cranking lever into the winch adaptor, and lower the roof by cranking counterclockwise until the roof stops. **DO NOT OVERCRANK.** The roof can be fully retracted and be 1 to 2 inches above the side walls. Do not continue to turn the cranking lever or damage to the lifter system will result.

NOTE: Make sure when pushing in the bunks and lowering the roof, that the tent is kept clear of the bunk slides and the lifter posts.

NOTE: If your camper has an awning, remove and store it when the roof is fully lowered.

26. Fasten the roof latches at each corner. It may be necessary to push down slightly on the roof at each corner to completely close roof section and allow the latches to close.
27. Hitch the camper to your tow vehicle.

NOTE: It is important to allow wet tent to dry completely before breaking camp. If you must leave soon after a rain storm, or just after dawn, be sure to protect all cushions and drapes from dampness. Mold and mildew will form inside the camper if fabrics and surfaces are allowed to be stored in this way. If dampness does occur, set the camper up again as soon as possible to allow it to air out and dry thoroughly. Refer to the index for locations in this manual of additional information regarding care of your camper.

LP GAS SYSTEM

GENERAL INFORMATION

The liquid petroleum (LP) gas system in your camping trailer furnishes the fuel for cooking, optional heating, and hot water. LP gas can also be used as an alternate energy source for refrigeration. LP gas is a clean, efficient, safe form of energy when proper handling and safety precautions are observed. It enables you to enjoy a comfortable life-style where other forms of energy are not easily utilized.

LP gas is stored as liquid in a special storage tank. The tank is mounted on the frame at the front of the camper near the hitch. The tank can be enclosed with an optional gas bottle vinyl cover. The cover also protects the tanks from the elements, and objects which might strike the tanks while towing the trailer. Double gas bottles and cover are an optional feature.

The gas is stored under extreme pressure in the tank, with space in the tank to allow for expansion into vapor. This vapor is reduced in pressure by passing through a regulator. This reduction in pressure is a two step process which assures consistent pressure for use, regardless of outside temperatures, weather, or altitude.

Your LP system is designed to accept either propane or butane. However, since butane vaporizes at about 32 degrees F, it can only be used in areas where you can be sure of higher temperatures. Propane vaporizes at approximately -40 degrees F. There are blends of propane and butane available, which will vary in the temperature at which it vaporizes. When filling your tank, select an LP gas that has a boiling point about 40 degrees lower than temperatures you expect to travel in. Talk to your **FOREST RIVER** dealer, or your local LP gas supplier about what you should be using.

LP GAS CONTAINERS

LP gas containers are designed with a substantial safety factor. This means that they are tested to withstand pressures in excess of what they would normally be subjected to. Additionally, every LP gas container has a safety filling feature built into it. They are designed to be filled only 80% full of liquid LP gas. Filling the container 80% full of liquid naturally allows 20% vapor space. This provides for

vapor withdrawal through the POL service valve, and also allows "expansion" space for the liquid. If the tank were completely full, a rise in outside temperature could result in possible relief valve discharge of LP gas.

Attaching the LP Gas Container to the Camper (20 lb. Bottle)

1. Attach the LP gas container bracket to the "A" frame using the two 1/4-20 NC hex head bolts provided.
2. Place the container into the bracket and tighten the clamp ring. Make sure the container is properly seated.
3. Attach the regulator assembly to the service valve (it has a left-handed thread).
4. Using a wrench, draw the POL nut up snug. **DO NOT OVERTIGHTEN.** This is a machined male brass fitting which seats against a female seat.

⚠ WARNING: Do not use pipe sealant on LP gas connections.

5. Make sure that the regulator vent faces downward and that regulator cover is kept in place to minimize vent blockage.

⚠ WARNING: Vent blockage can result in excessive gas pressure, which can cause fire or explosion. Always keep the regulator protective cover in place to minimize this danger and protect the regulator from the elements.

6. Connect the low pressure flexible hose to the regulator first, then attach the free end to the manifold.
7. Before opening the service valve allowing LP gas to flow into the system, be sure all LP gas appliances are turned off.
8. Open the service valve and check all connections for leaks, as outlined further in this section.
9. Follow the manufacturer's instructions carefully when lighting an LP gas appliance.

Never use any other LP tank than the one furnished with your camper. If the tank must be replaced, check with your **FOREST RIVER** dealer for correct tank specifications and replacement procedure. Make sure to keep the tank securely mounted in its proper position for use. Use all the hardware provided to insure proper support and position.

⚠ WARNING: Make sure the tank service valve is accessible at all times. In an emergency, it may be necessary to shut off the valve quickly.

FILLING LP GAS CONTAINERS

Before removing the LP gas container for refilling, or doing any work on the LP system, always extinguish open flames and smoking materials.

To have the container filled, proceed as follows:

1. Make sure all LP appliances have been turned off and their pilot lights are extinguished.
2. Close the service valve on the LP container and remove the regulator. Be careful when removing the regulator, not to use excessive force. The regulator P.O.L. connection has a left-handed thread and must be turned clockwise to remove. Never use a wrench to close the service valve or 20% gauge. If when

closing by hand, leaking occurs, have the valve repaired or replaced.

3. Cap or seal valve inlet to prevent the entrance of dust and dirt.
4. Loosen the clamp ring bolt and remove the container from the camper. Always transport the LP gas bottle in the upright position. Never transport, install, or use a vertical tank in a horizontal or upside down position.
5. Take the container to a qualified LP gas supplier.
6. Have supplier connect the fill nozzle to your tank fill connection.
7. Even though the tank is equipped with an automatic 80% shut-off which prevents overfilling beyond 80% tank capacity, it is a good idea to have the supplier monitor the 20% liquid level gauge, and stop the filling process if liquid does appear.
8. Never use any other tank than the one furnished with your camping trailer. If the tank must be replaced, check with your **FOREST RIVER** dealer for correct tank specifications and replacement procedure.

⚠ WARNING: Make sure that the tank is not filled beyond the 80% liquid level. If the tank has been overfilled, make sure the LP supplier bleeds out the excess. Overfilling the LP gas container does not allow for the necessary 20% vapor expansion space that can result in uncontrolled gas flow which can cause fire or explosion.

LP GAS REGULATOR

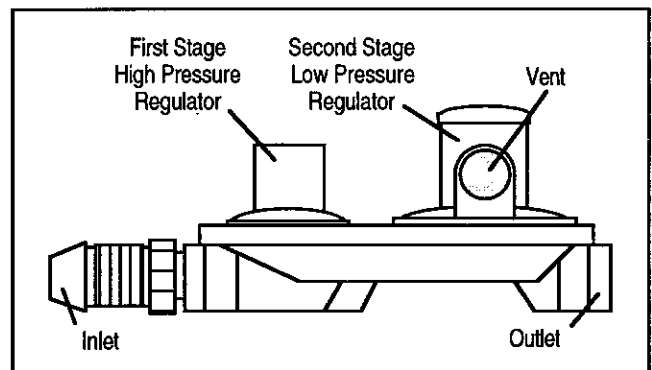

Two Stage LP Gas Regulator

The regulator reduces the pressure of the LP gas vapor from the pressure in the tank, to the pressure required for use at the appliances. The regulator seldom requires service, but it should always be protected from the elements and extremes of hot and cold.

The regulator has been preset by the manufacturer of the regulator, and adjustment should not be necessary. If adjustment should be required however, **DO NOT** attempt to adjust yourself. Adjustment must be made with special equipment by a qualified LP gas service technician. Have the regulator checked annually, or whenever you suspect a problem. The correct line pressure should be 6 to 8 ounces, or 10 to 14 inches of water column.

⚠ WARNING: Never alter the positioning of the regulator. LP gas regulators must always be installed with the diaphragm vent facing downward. Also make sure to keep the regulator cover in place to minimize vent blockage which could result in excessive gas pressure causing fire or explosion.

Because air is required for proper operation of the regulator, it is very important that the regulator vent is kept clean and free of dirt and

debris. This is why it is necessary to keep the vent facing downward and the regulator covered to protect it from contamination. A toothbrush can be used to clean the vent if it becomes clogged by foreign matter.

During cold weather, it's important to keep ice from forming in the regulator, which will shut off the flow of LP gas to your appliances. Have your LP supplier add anhydrous methanol when filling your tank for use during cold weather. Regulator freeze up can occur in any weather, if there is moisture in the tank, or the tank has been overfilled. Always use moisture-free LP gas, and make sure the tank has not been filled beyond 80% of capacity. If moisture has entered the tank, have the tank purged, or have anhydrous methanol added by an authorized LP supplier.

A two-stage regulator performs the pressure reducing function as previously described, but it is accomplished in two stages. Two regulators are used in the same body to reduce the pressure of the LP gas in the tanks for use by the appliances in the trailer. The high pressure regulator (first stage) is used to reduce the pressure to approximately 10 to 13 PSI before sending it along to the low pressure regulator (second stage). This second stage regulator reduces the pressure further to 11 inches water column, or 6.35 ounces per square inch.

The two stage regulator does not have to work as hard since the second stage receives consistent pressure rather than inlet pressure which varies. The result is an efficient safer system that helps to eliminate problems such as freeze up and pilot outages.

REGULATOR FREEZE-UP

The term regulator freeze-up is a misleading one. Regulators and LP gas do not freeze. However, the moisture that can be contained in the gas will freeze as the gas expands and cools passing through the regulator. This freezing of the moisture in the gas can build up and partially or totally block the passage of the gas through the regulator. Freezing can also occur when outside temperatures are low enough to contribute to the freezing of the moisture in the gas.

The source of the moisture is varied. It can occur at the refinery or gas bulk plant, in the cars used to transport the gas, or even within your own LP tanks. Moisture in an LP tank can occur when a tank service valve is left open, allowing moist air to enter and become trapped.

A two-stage regulator helps to reduce the possibility of freeze-up because of its larger orifice size, and the fact that heat is transferred through the walls of two regulators instead of just one.

There are several steps that can be taken to inhibit or prevent this from happening:

- Make sure that your LP tank is free of moisture before refilling.
- DO NOT overfill the LP tank.
- Make sure to keep the service valves on an empty tank closed.
- If freezing has occurred, have your LP dealer purge the LP tank before refilling.
- Add anhydrous methanol or other approved LP antifreeze or deicing agent to the LP tank.
- Keep the regulator covered at all times.

If freeze up does occur, NEVER attempt to thaw with an open flame. A small light bulb can sometimes be useful to provide heat and aid the thawing process. Once thawed, be sure to take the proper steps to prevent a reoccurrence. Have the system checked by your LP supplier if freeze-up continues.

Other Cold Weather Factors:

Remember that as outside temperatures drop, the BTU value of the LP gas is lessened, since the colder liquid LP in the tanks requires the heat from the surrounding air to vaporize. This lowering of BTU value can significantly affect the performance of the system. You can help insure proper performance by keeping your LP tanks as full as possible in cold weather, and reviewing the BTU/hr rating plates on LP appliances for proper LP management.

LP SYSTEM HOSES AND FITTINGS

The hose used with your camper's LP system is designed to withstand pressures far exceeding those of the LP system. However, because sunlight and ozone both contribute to the deterioration of the hose, they must be inspected for wear at regular intervals. The average life of an LP hose is about 2 to 3 years. Be sure to inspect the hose before each camping season, and when having the tank refilled. Look for signs of deterioration such as cracks or loss of flexibility. It is a good idea to protect the hose from the direct rays of the sun whenever possible to help slow down the aging process. When the hose is replaced, make sure to always replace it with a hose of the same type and rating (check with your dealer).

Fittings are used to connect the various hoses and system components to each other. The P.O.L. fitting at the end of each LP supply hose is the fitting that you will be disconnecting whenever it is necessary to remove a tank for refilling. It is made of brass so that pipe sealants are not necessary to prevent leaking. It also has a left-handed thread, which means that you turn it clockwise to remove, and counter-clockwise to tighten. If leakage is observed at the P.O.L., and normal tightening of the fitting does not correct the problem, it will be necessary to replace the entire hose assembly. (It is also a good idea to have the other components of the system checked out by a qualified LP service representative at this time.)

The P.O.L. fitting has been designed to help restrict the flow of LP gas in the event of a regulator failure, or hose malfunction. Because of this excess flow device inside of the fitting, it can sometimes restrict the flow of fuel to the various appliances within the camping trailer. If you notice that gas flow to your appliances has been restricted, the following procedure should be used to help eliminate the problem:

1. Make sure all the appliances have been turned off (including pilot lights if applicable), and that there is no gas flowing into the system.
2. Make sure that the system is free of leaks (review how to test the system for leaks in this section).
3. Open the LP tank service valve slowly (DO NOT SNAP IT OPEN). If opened too quickly, the excess flow control may think that the system has been damaged due to the sudden pressure fluctuation.
4. Wait for at least 15 seconds before lighting any pilot light or appliance.

If followed, this procedure should create a normal flow of LP gas by allowing the excess flow control to settle in slowly.

On models equipped with optional double tanks and optional automatic changeover, both hoses from the individual LP tanks are connected by a tee to the regulator. This tee contains a disc check valve that prevents the LP gas from escaping when an empty tank is disconnected to be refilled.

CHECKING LP SYSTEM FOR LEAKS

Road vibration can loosen LP gas fittings and connections. It is important to check your LP system for leaks at least every 5000 towing miles, and whenever the tank is filled. Making an inspection of LP components a regular part of your campsite set-up can help to identify potential problems before they occur. It is also a good idea to have your entire LP gas system checked annually by a qualified LP gas service representative.

Use the following steps when checking the system for leaks:

1. Open all the windows and roof vent.
2. Open the gas tank service valve.
3. Use non-ammoniated, non-chlorinated soap solution, or an approved leak detection solution on all line connections (ammoniated soap solutions can cause cracking on copper or brass lines and fittings). Bubbles will be formed by escaping gas, indicating a leak.
4. If a leak is detected, tighten the connection with two open end wrenches until bubbling stops. **DO NOT** overtighten, or use excessive force. If leak continues, contact your **FOREST RIVER** dealer, or a qualified LP gas service representative. **DO NOT** use tools to tighten tank service valves.

5. Check LP piping where contact with the frame could cause cracking or damage due to vibration or road shocks.

⚠ WARNING: *Never check for leaks with an open flame. Also, never attempt LP repairs without the proper knowledge and tools to accomplish the job.*

The scent of LP gas (a garlic-like odor) is actually ethyl mercaptan, an additive that allows you to detect the presence of a leak, since LP gas is naturally odorless.

LP GAS SAFETY PRECAUTIONS

⚠ WARNING: *DO NOT store LP gas containers inside the camping trailer. LP gas containers are equipped with safety devices which relieve excessive pressure by discharging gas to the atmosphere.*

Be careful when doing any work or maintenance in the camper, that you do not puncture a gas line with a nail, screw, or drill bit.

A complete listing of the LP gas warning labels and decals used throughout the camping trailer can be found in the Introduction section of this manual. They are located in the camper in locations where the potential for a dangerous situation is present. They have been installed not only because of the requirement to do so, but also as a constant reminder to occupants of the camper to exercise proper caution when using or being around LP gas appliances and equipment. Make sure that you and your family understand and follow all of them. Never remove these warning labels and decals. If one should be lost, it should be replaced as soon as possible.

Typical LP Gas System

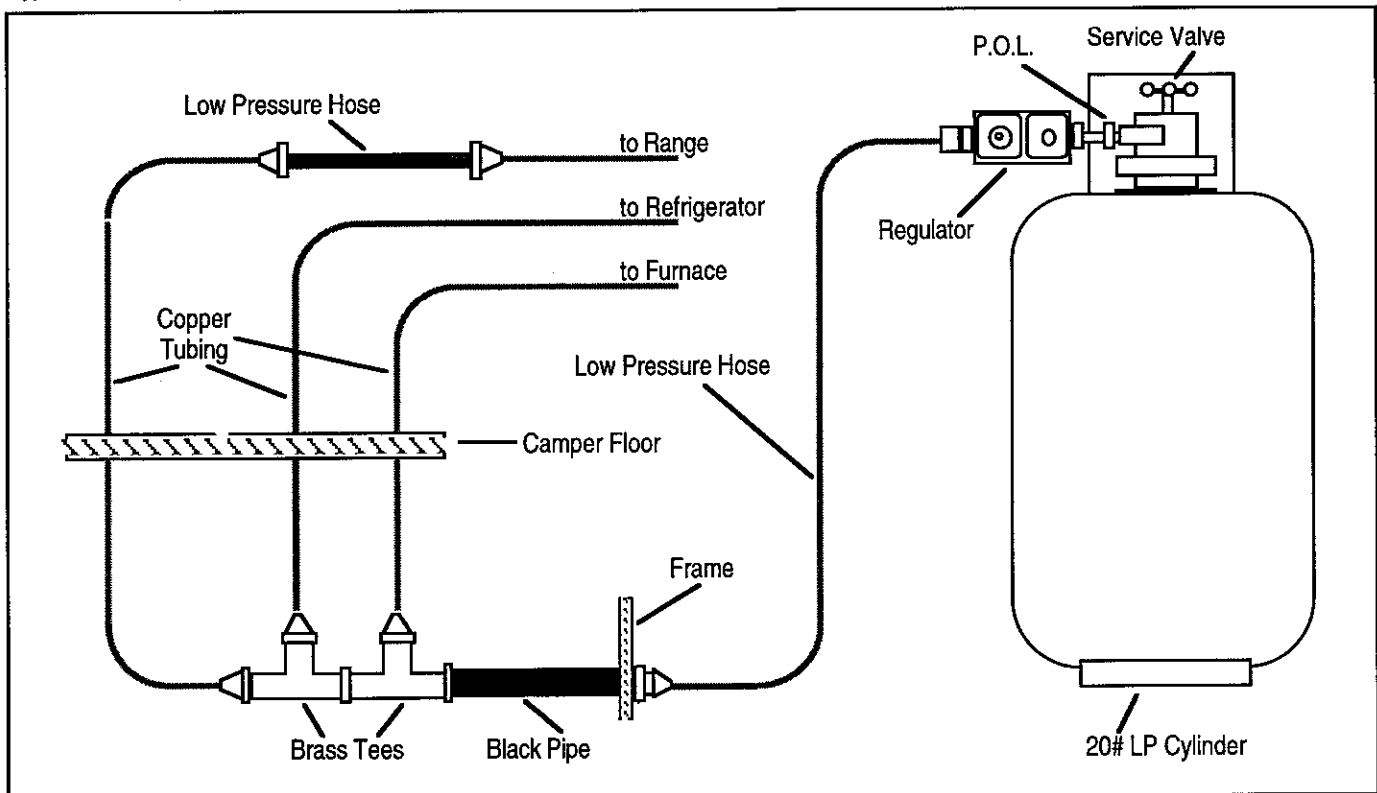

ELECTRICAL SYSTEM

12 VOLT SYSTEM

12 volt functions of the camper include both the interior and exterior lighting, as well as the optional water pump, furnace, and refrigerator.

12 volt power for exterior vehicular lights is supplied by the tow vehicle through the pigtail connection. Interior 12 volt lighting can also be supplied by the tow vehicle, but prolonged use will run the battery down. A three position switch on the converter needs to be placed in the battery position to operate interior lights in this manner.

A power converter in the camper converts 110 volt electricity from an exterior source into 12 volt power for operation of the interior lights. There are no provisions for running additional 12 volt accessories from the converter, other than the blower on the furnace. The refrigerator is wired to operate on 12 volt battery power only. Never attempt to re-wire the refrigerator to operate on 12 volt power from the converter. Operation of the converter is controlled by a 3-way switch located at the converter. The 3 positions consist of OFF (for storage and towing), CONVERTER (when an outside 110V source of power is available), and BATTERY (when no outside source of power is available to operate the lights).

NOTE: The power converter is not to be used to charge batteries.

12 volt operation of the optional refrigerator is provided so that it is able to run through the tow vehicle pigtail connection while traveling. Do not try to run the refrigerator this way while camping. If you will be stopping for more than one hour while operating the refrigerator in 12 volt mode from the tow vehicle, you should switch operation of the refrigerator over to LP gas to keep from draining the tow vehicle battery.

12 VOLT BULBS AND FUSES

There is a 12 volt fuse located at the converter. Make sure to check for the cause of a blown fuse before replacing it. Never replace a fuse with a fuse of a higher amperage.

NOTE: If your camper is equipped with a shower, an additional fuse is located at the converter because of the 12 volt water pump.

Bulb Replacement Sizes:

Exterior

Tail Light.....	#1157
Clearance Lights	#C193
Porch Light	#93

Interior

Overhead	#CEC1003
----------------	----------

WARNING: Make sure to turn off all interior lights when closing up the camper for storage or towing. Heat from interior light bulbs when the camper is closed up is a fire hazard.

Sometimes, a "short" along the line can cause the blowing of the fuse. Locate the "short" and take necessary steps to repair it. If you cannot locate the problem, have a qualified electrician check it out.

Exterior 12 volt electrical components such as the brake and tail lights are fused through the electrical system of the tow vehicle.

Check the tow vehicle owner's manual for the location of, and proper method of replacing 12 volt fuses and components.

It is a good idea to keep an additional fuse on hand in the camper. It is also a good idea to keep a supply of 12 volt bulbs on hand. Replacement fuses and bulbs are available at filling stations, hardware stores, or automotive supply stores. Remember that the replacement fuse or bulb must be the same amperage rating, type, or equivalent as the original.

110 VOLT SYSTEM

The camper can be hooked up to an external 110 volt power source for operation of the convenience outlets and 110 volt operation of the optional refrigerator. To attach to an outside power source, open the cap on the power cord storage compartment, and pull out the cord. A cutout on the cap allows you to replace the cap over the cord to keep water and dirt from entering the cord storage compartment. The power cord is 25 feet in length, and designed for 30 amp service.

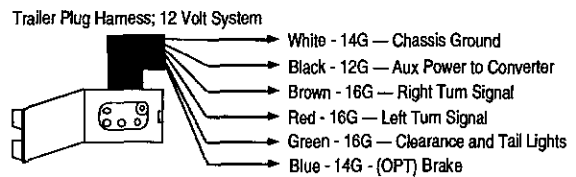

Shore Line Cord (12-2 Romex With Ground); 110 Volt System

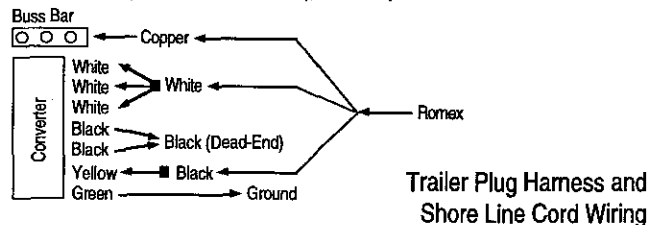

WARNING: Connecting the power cord to a non-grounded or improperly grounded power source can result in a dangerous and possible fatal electrical shock. Because of the potential danger in failing to heed this warning, FOREST RIVER'S warranty of fitness and merchantability, as well as any other expressed warranties made in connection with this sale, shall not be effective or actionable should damage, injury, or death result from failure to connect the power cord to a properly grounded power source.

WARNING: NEVER use a two wire extension cord and adapter without proper grounding, or put an ungrounded plug on your power cord in place of the molded 30 amp plug.

When attached to the exterior power source, make sure to put the three position switch on the converter in the proper position. The converter has two 15 amp circuit breakers built in for overload protection (if roof air kit installed, one breaker will be 20 amp). The breaker is "ON" when the button is pushed in, and "OFF" when the button is pulled out (green band showing). If a circuit breaker has been tripped, do not reset the breaker until the cause of the problem is identified and corrected.

NOTE: Some electrical appliances may have their own circuit breakers. If there is an interruption in electrical service involving an electrical appliance, consult the owner's manual for that appliance to determine what action to take.

BATTERY BOX AND CHARGER

A battery box and charger is available as an option for any camper. The battery box is located behind the LP tank on the front of the camper. A lid on the battery box covers and protects the battery. The lid can be protected with a lock if desired for additional security.

It is important to make sure that the battery is kept charged, so that it will be available for use when needed. Take time to turn off all lights or other 12 Volt conveniences when not in use. Connect the camping trailer to a 110 Volt power supply when possible, instead of draining the battery. Make sure to disconnect the battery if the camper will be unused for more than a week.

The battery can be used to provide 12 volt power for lights when an outside source of power is unavailable. The battery is recharged from the charger when it is attached to an outside 110 volt power supply (the charger must be plugged in to operate).

Make sure to follow good battery maintenance and safety procedures such as are outlined in your tow vehicle's owner's manual.

GROUND FAULT CIRCUIT INTERRUPTER

The 110 volt patio outlet is equipped with a protective circuit interrupter. The ground fault circuit interrupter (GFCI), is designed to break the flow of current to the protected outlet when an imbalance of current is detected. Imbalances include electrical leakage in an appliance that has developed a weak spot in electrical insulation. The possibility of electrocution exists when using a faulty appliance, while at the same time being in contact with an electrical ground such as water or the earth. If an imbalance is detected, the GFCI will trip and shut off power to the outlet. Even with GFCI protection, the electrical shock will still be felt, but to a lesser degree. It also does not protect against short circuits or system overloads. The circuit breaker in the main panel which supplies power to the circuit, will trip if either of these conditions exist.

The GFCI receptacle should be tested initially when the camper is purchased, and at least monthly thereafter.

To test the circuit, use the following procedure:

1. Make sure power is on to the circuit.
2. Push the test button.
3. The red reset button should pop out.
4. All power should be interrupted to outlets protected by the GFCI.
5. Verify by plugging in a light at these outlets, and pushing in the reset button.

If the red reset button does not pop out after pushing the test button, or the GFCI circuit continues to trip, immediately turn off the power at the circuit breaker panel and have a qualified electrician check it out.

⚠ WARNING: *Even with GFCI protection, persons with severe heart or other health problems may still be seriously affected by an electrical shock. The GFCI outlet is not a substitute for good electrical safety. It DOES NOT protect against contact of the hot and neutral wire at the same time.*

NOTE: *The GFCI does not protect any circuit other than the one to which it is connected.*

WATER & DRAINAGE SYSTEM

Fresh water for your camper can be supplied in two ways. You can utilize water from an internal supply that you carry with you in the camper's fresh water tank, or from an external pressurized source. Components of the camper's water system consist of strong, light-weight, corrosion resistant materials that provide long life, and easy cleaning. By following the instructions for water system use outlined in this manual, you can expect efficient operation with a minimum of maintenance.

FRESH WATER TANK

Your internal water supply tank is filled through a gravity fill spout located on the side of the camper. Two styles of fill spouts are used. To fill the style equipped with a hinged lid, slide the locking lever to the side to release and lift the protective cover. The other style has a cap that screws off for access. In either case, water can be added to the tank by use of a bucket or hose. It is a good idea to use a different color hose for filling the fresh water tank than the one used for drainage, so that you will know at a glance which is which. If using a container such as a bucket to fill the tank, label it some way so that it will be used only for this purpose.

⚠ WARNING: *Always fill the tank with clean drinkable water from a known safe source. Make sure to close the lid on the gravity fill spout to maintain system security. Also, always fill the system with a hose or bucket that you know is clean, and is used only for this purpose.*

Water can be drawn from the supply tank by pumping the galley faucet several times to prime the system for use. Once water has been drawn through the faucet, it will not be necessary to pump the galley faucet lever as many times to supply water.

NOTE: *When the system is filled, make sure to check for any leakage. If the galley pump connection is loose, it will not be possible to create the vacuum needed to draw water from the tank.*

Water in the supply tank can be drained by opening the drain cock located beside the water tank inside the camper. Lift the drain cock handle to drain the tank. Push the handle back down to close the valve. The drain valve for campers with tanks below the floor is located under the camper beside the gravity fill spout.

Pressurized Water Supply

To utilize water from an external pressurized source (city water), proceed as follows:

1. Make sure the galley faucet is in the off position.
2. Remove the cap from the city water connection on the side of the camper. It will be located on outside wall near the sink.
3. Connect a good quality hose to both the camper connection, and the connection at the city water supply. It is a good idea to use hoses of different colors for the supply and drain lines to avoid possible contamination of your water system.
4. Turn the city water supply on. Open the galley faucet by pressing down to test for proper flow. Make sure there are no kinks in your hose that restrict the flow.

NOTE: *A check valve in the system prevents filling of internal storage tank.*

WATER PUMP

When using water from the fresh water tank, the system must be pressurized. A self-priming 12V DC pump is provided to handle this function. A pump ON/OFF switch is located on the backside of the dinette next to the converter. When the switch is in the ON position, an indicator light on the switch illuminates to let you know the pump has been activated. Once activated, the pump will turn itself on automatically whenever a faucet or valve is opened; creating a demand for water. Once the water flow is shut off, the pump also shuts off. Sometimes, when using the pump for the first time after filling the fresh water tank, the water flowing from the faucet will sputter until all the air has been cleared from the water line. This is normal, and not a problem with the pump. When using the internal water supply, the pump should be left on, since it only runs when there is a demand for water from the system.

⚠ WARNING: *DO NOT* turn the water pump ON when using water from an outside pressurized source.

FILLING THE SYSTEM

If your camper is equipped with a shower, you should allow the entire system (water tank, water heater, and water lines) to fill with water, so that the water heater can be utilized. When using water from either an internal or external source, open the faucets to allow water to flow through the system. When the flow becomes steady and free of air, turn off the faucets. Make sure that the water heater has been filled before lighting the pilot.

NOTE: *When using the internal supply, you may want to add additional water to the system to replace the water used during the process of allowing all components of the system to fill.*

DRAINAGE

The sink drain is a direct connection to the drain fitting on the side of the camper. As water is used, it should be drained through a hose directly into the campsite septic system, or if not available, into a bucket for proper disposal.

NOTE: *Never allow water you have used to drain directly onto the ground.*

CASSETTE PORTA POTTI

A cassette porta potti is available on some camper models. It is constructed of high quality plastic for durability and easy cleaning and maintenance. It consists of two sections; a permanently installed toilet system and a slide out waste holding tank (cassette).

The toilet section includes a seat and cover, flush and valve blade opener knob, toilet tissue compartment and holder, waste level indicator, built-in toilet fluid storage compartment, a drip tray - a drain tube assembly and level indicator for the fresh water tank, and a fresh water tank.

The cassette section is located underneath the toilet and is removed for emptying from outside the camper through an access door. A rotating pour-out spout, automatic holding tank vent, air release valve, blade, carrying handles and hand grips are incorporated into the cassette.

Other features include a safety sensor switch that guards against adding water to the bowl without the cassette in proper position.

For complete operating, cleaning, maintenance, and winterizing/storage instructions, refer to the instructions supplied with the porta potti. Make sure to pay particular attention to any notes or cautions associated with its use. Also be sure to complete and return any warranty registration with the manufacturer.

SANITIZING POTABLE WATER SYSTEM

Sanitize the system before initial use, after extended periods of non-use, and whenever there is a suspicion that the system has been contaminated. To sanitize the system, use the following procedure:

1. Prepare a chlorine solution using a gallon of water and 1/4 cup of liquid household bleach (5% sodium hypochlorite solution). Use one gallon of solution for each 15 gallons of tank capacity.
2. With the tank empty, and all faucets and drains closed, pour the solution into the fresh water tank.
3. Complete filling the tank with fresh water.
4. Use the galley pump faucet until water flows freely from it.
5. Again add fresh water to the tank until water level reaches the fill spout.
6. Allow the system to stand undisturbed for a few hours (at least three).
7. Drain the system by opening the galley faucet, and the supply tank drain cock, while flushing the system with water of drinking quality.
8. Continue flushing system, allowing water to flow for several minutes.
9. Close the tank drain valve and the faucet. Refill the system with water of known drinking quality.

NOTE: *If the taste or odor of the chlorine solution used to sanitize the system lingers, pour a solution of 5 gallons of water mixed with a quart of vinegar into the tank. Agitate the solution in the tank by towing the camper, then allow it to sit in tank for another day or two. Drain the tank, fill and flush with fresh water, and refill with fresh water of drinking quality.*

If you are unsure of the quality of the drinking water you are adding to your system, it can be disinfected by using 8 drops of household bleach for each gallon of water added.

DRAINING THE SYSTEM

The water system should be drained when not in use. To drain, proceed as follows:

1. Open the galley faucet and the supply tank drain cock.
2. When the tank is drained, pump the galley faucet several times to expel any water in the faucet and supply line.

For the models with a shower, additional draining requirements will include the water pump and the water heater. There are also additional low point drain valves on the water lines of some models. Check the water lines on your camper for any low point drains that may need to be opened to completely drain the system. In addition, ask your dealer about drainage requirements for your particular camper model. Refer to winter storage instructions for additional information on draining the system.

WATER SYSTEM MAINTENANCE AND TROUBLESHOOTING

As with any mechanical system, your plumbing is subject to the development of problems. Most of these problems can be greatly reduced if not altogether eliminated by following a schedule of planned inspections and maintenance. Neglect of proper maintenance procedures is the usual cause of most water system problems.

Road vibrations and shocks, as well as the excessive pressure from some city water sources are the main physical causes of water system damage. It is important to inspect all plumbing joints and fittings often for cracks and leaks. Water leaking from a plumbing joint can cause considerable damage if left unchecked.

A leak somewhere in the fresh water system should be suspected whenever the pump is running and all faucets and valves are closed. When the leaking fitting has been identified, attempt to stop the leak by tightening. **DO NOT** overtighten. Plastic fittings rarely need to be tightened with a wrench. If these fittings leak after tightening by hand, disconnect the fitting and check for dirt, scale, or other foreign substances which may be causing the leak. Clean the fitting thoroughly and reinstall. If leaking persists, shut off the water supply until the fitting can be properly replaced. Check with your dealer for correct method of replacement, and replacement parts.

Proper winterization procedures of plumbing systems will normally be all that is necessary to prevent the damage caused by freezing. Freezing damage can harm any component of the system, including the water tank, pump, water heater, and all piping. Be sure to follow the winterization procedures outlined in this manual. Also be sure to discuss any additional precautions that should be taken to winterize your camper's plumbing system with your dealer. Local climates vary; and winter maintenance needs may be affected.

Be sure to read the literature supplied with plumbing components, such as the pump, for troubleshooting tips. Also remember that it is possible for an electrical problem to cause water system problems. Lack of power to the pump can be caused by a variety of reasons. If you are unsure of how to locate and/or repair a plumbing problem, it is best to have your dealer or a qualified plumber handle the job.

APPLIANCES

GENERAL INFORMATION

The various appliances in your camping trailer will provide home-like convenience while traveling. They have been designed and tested by their manufacturers for maximum service in a camping trailer application.

Each appliance in your camper is covered by **FOREST RIVER'S** comprehensive warranty as well as being additionally warranted by its respective manufacturer. Refer to the Introduction section of this manual for a listing of the appliances, and any additional warranty they may have. Be aware however, that constant improvement in design of the camping trailer may mean that an appliance in your camper may not yet be covered in this manual. It is extremely important that you review all the literature provided in the manufacturer's information package provided with your camper. Fill

out and mail any warranty registration cards required by the appliance manufacturer at this time. Be sure to have your dealer go over the operation of the appliances with you, and report any shortages of literature you may have at that time.

It is important that you also carefully read all the manufacturer's information provided regarding both operation and maintenance of the appliances. Pay close attention to all safety precautions given, and make sure to follow them. If the instructions for the operation of any appliance differ from the instructions outlined in this manual, make sure to use the information provided with the appliance.

Be sure to keep all literature, including this manual with the camping trailer for easy reference. If service on any appliance is required, contact your **FOREST RIVER** dealer, or an authorized service representative of the appliance manufacturer.

Appliances available in the camper include the range, and the optional furnace, refrigerator, and water heater. The following operating information is general in nature. Additional operating instructions can be found in the literature provided with each appliance in the manufacturer's information package.

▲ WARNING: *Make sure to read and follow all directions pertaining to the use and care of LP gas appliances provided in the manufacturer's information package.*

NOTE: *Sometimes it may be necessary to purge the air from an LP gas line before an appliance can be initially lit.*

RANGE

The range in your camper will be either a two or three burner style. In either case, there is no pilot light under the range top that must be lit. Each burner is lit individually by pushing in on the burner control knob, rotating it to a setting somewhere above the medium range, and holding a lighted match to the burner.

NOTE: *Longer stick matches are a good idea for lighting the range, because they keep your fingers away from the direct flame. Make sure to have the match lit and ready when turning on the burner, so that there is no delay allowing excess gas to accumulate.*

▲ WARNING: DO NOT *light a match if you detect the odor of LP gas before attempting to light the range. Follow all safety procedures associated with the use of an LP gas appliance and system.*

When lit, adjust the flame to the desired level with the control knob. Turn the control knob all the way to the OFF position to extinguish the flame, and shut off the gas.

▲ WARNING: DO NOT *use the range to heat the camper. The open flames of the burners can consume the oxygen available in the unit.*

Make sure to read all literature provided with the range, and follow all operating instructions and safety precautions outlined in it. Never leave the range unattended when lit.

WATER HEATER

The water heater is provided with the shower on the models so equipped. It is part of a system that includes additional water storage capacity, a 12 volt water pump for self contained operation, and the plumbing for hot water to both the shower and the kitchen.

The water heater can be used with either the self contained fresh water system, or when the camper is connected to an outside source. Make sure the water heater has been filled before attempting to light.

Read all literature provided with the water heater before attempting to use it. Pay particular attention to any cautions or warnings associated with its use.

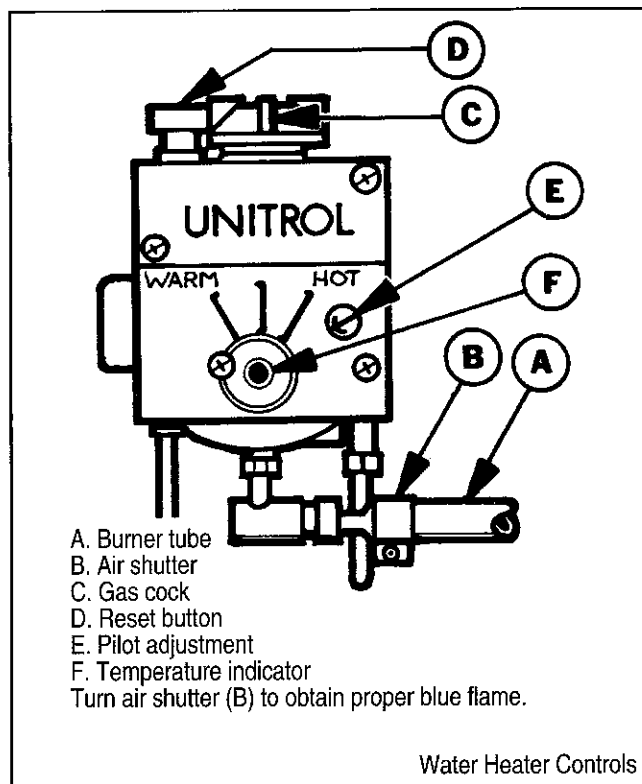

To light the water heater, proceed as follows:

1. Open the vented access door.
2. Make sure the LP gas shut-off valve is in the OFF position. If not, shut it off and wait at least five minutes for any gas to dissipate before attempting to light.
3. Press the reset button and hold while lighting the pilot through the burner tube.
4. Continue to hold the reset button down until the pilot remains lit, and then turn the control to the ON position.
5. Set the temperature control at the desired level.

⚠ WARNING: Setting the temperature past the 130° F position increases the risk of scald injury.

⚠ WARNING: If the water heater does not light on the first attempt, shut off the water heater gas valve, and allow the LP gas that is present to dissipate for five minutes before attempting to relight. **DO NOT** attempt to light if you detect the odor of LP gas. **DO NOT** light until water heater has been filled.

Make sure to completely drain the water heater when winterizing the fresh water system. Check the literature provided with the water heater for the location of the water heater drain valve, and the correct method for draining.

FURNACE

Your camper may be equipped with an optional furnace. The furnace is a 17,000 BTU unit capable of heating up to and maintaining a comfortable temperature level in the camper. A separate thermostat in the camper allows easy adjustment of interior temperatures.

Lighting Instructions - Make sure to follow these lighting instructions exactly to avoid possible damage to the furnace.

1. Press gas valve knob in and turn to OFF.
2. Set the thermostat to the highest setting, turn the ON/OFF switch to ON, wait 5 minutes.
3. Turn the gas valve knob to the PILOT position. The blower should be running.
4. Press the gas valve knob in and light the pilot by pushing in on the ignitor repeatedly until the pilot lights. Hold the gas valve knob in for one minute or until the pilot remains lit.
5. Set thermostat to the desired temperature (fan should be running), then turn the gas valve knob to the ON position.

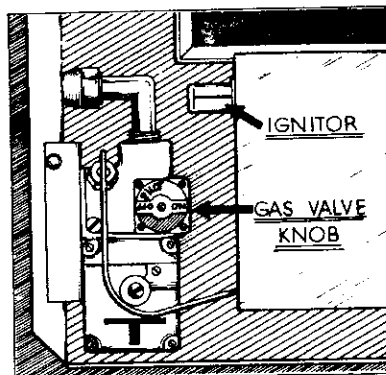

Complete Shutdown - Turn the gas valve knob to the PILOT position. Depress and turn to OFF position and the thermostat to the OFF position.

Sequence of Operation - When the wall thermostat contacts close, a time delayed relay is energized. After a 15 second delay, the motor starts turning the circulation and combustion wheels. When the blower reaches the RPM's necessary to close the air operated sail switch, power is supplied through a temperature limit switch to open the main gas valve. The burner is then ignited by the pilot flame. When the wall thermostat contact opens, the fan relay is de-energized, the gas valve closes, and the blower motor stops running after 45 seconds to 2 minutes. This is a cool down period, and is normal.

Read and follow all instructions provided with the furnace regarding the lighting, adjustment, and any precautions and warnings associated with its use.

NOTE: Make sure not to block the furnace inlet and exhaust vent.

REFRIGERATOR

The camper can be equipped with an optional refrigerator instead of the standard insulated icebox. Some models can be powered by LP gas, 12 volt electric, or 110 volt electric power (3-way). **MAKE SURE** to read the owner's manual furnished with your

refrigerator for complete instructions regarding its operation and maintenance.

Operate the refrigerator with 12 volt power supplied by the tow vehicle through the pig-tail only when towing the camper. Do not continue to run the refrigerator from the tow vehicle electrical system if you will be parked for more than an hour. This will help you keep from draining the tow vehicle battery. Switch refrigerator operation to LP gas when parked (refrigerators on some models can also operate on 110 volt power when available). Don't forget to switch back to 12 volt operation when resuming travel.

Controls for the operation of the refrigerator are located at the rear of the unit, and are accessible through the lower ventilator in the outside wall of the camper. The gas shut-off valve and the electric voltage-change switch are interlocked so that both methods of operation cannot inadvertently be used at the same time. The lower ventilator is removed by turning the handle of its catch 90 degrees counterclockwise, and pulling the cover out. Never cover or partially cover the air vents which would obstruct the flow of combustion and ventilation air.

Make sure to refer to the operating instructions supplied with the model refrigerator that you have. The normal thermostat knob setting for food storage is 3 or 4 (mid range), but adjustment may be

made depending on your cooling needs. Do not attempt to make ice with the unit until it has reached its normal cooling temperature. Efficiency of operation can be increased by placing pre-cooled items only into the refrigerator.

NOTE: *It is important to make sure that the refrigerator is level before attempting to start. Once started, the movement encountered during driving should not affect operation. However, when the camper is parked, the sensitivity of the refrigerator to be level should be remembered.*

When the camper is to be stored for any length of time, the refrigerator should be cleaned, and the door left ajar. The ice trays should be dried and kept outside the cabinet. Also make sure to defrost the refrigerator at regular intervals. Refer to the refrigerator manufacturer's instructions for proper defrosting procedures.

NOTE: *While traveling, the refrigerator door should be locked with the travel catch to prevent it from opening due to shifting of the contents, movement of the camper, etc. Also, make sure all containers in the refrigerator are tightly covered to avoid spills. Keep food items arranged to provide free air circulation for proper cooling. **DO NOT** cover shelves with paper or large containers.*

Make sure that your dealer completes the retail predelivery inspection form supplied with your trailer, and that both you and the dealer sign and date it before returning to FOREST RIVER to register your warranty within 10 days of purchase.

Your satisfaction and goodwill are important to your RV dealer and to Forest River. If you experience a problem with repairs made to your recreational vehicle, review the matter with the RV dealership's service manager. In most cases these complaints are resolved in this manner. If not, contact the owner or general manager of the dealership. If your problem cannot be resolved by the RV dealership, contact the Forest River warranty/customer service representative at 219-642-2640 ext.105.

When calling, please have the following information ready:

1. Your Forest River I.D. number
2. Name and location of the dealer you purchased your RV from
3. The date of your purchase
4. The nature of the problem

Or write to: Forest River, Inc.
Warranty/Customer Service
P.O. Box 124
Goshen, IN 46527

Forest River has a factory service center in Goshen, Indiana which is available for major service work that may be required. Service work is generally done on an appointment basis only. It is best to schedule an appointment well in advance with the service manager.

If you would like to schedule an appointment for service, please contact the service manager at 219-533-5934 or write to: Service Manager
Forest River, Inc.
P.O. Box 124
Goshen, IN 46527

SAMPLE

FOREST RIVER RETAIL PREDELIVERY INSPECTION		
ID Number _____	Forest River Serial Number _____	
Purchaser's Name _____		
Address _____		
City _____	State _____	Zip _____
Selling Dealer _____		
City _____	State _____	Zip _____
<p>LP SYSTEM</p> <input type="checkbox"/> Gas Bottle Placed, Purged & Filled <input type="checkbox"/> Regulator* <input type="checkbox"/> a. 10 in. W.C. Pressure* <input type="checkbox"/> b. Leak Test - No bleed down* <input type="checkbox"/> All Gas Appliances Function Properly* <input type="checkbox"/> Furnace* if installed <input type="checkbox"/> Range <input type="checkbox"/> Refrigerator* if installed <input type="checkbox"/> Water Heater* if installed <p>12V ELECTRICAL</p> <input type="checkbox"/> Batteries & Charger if installed <input type="checkbox"/> Power Converter <input type="checkbox"/> Fuse Panel <input type="checkbox"/> Refrigerator, if applicable <input type="checkbox"/> Smoke Detector <input type="checkbox"/> Interior Lights <input type="checkbox"/> Exterior Lighting <input type="checkbox"/> Tail & License Lights <input type="checkbox"/> Clearance Lights <input type="checkbox"/> Porch Lights <p>EXTERIOR</p> <input type="checkbox"/> Tire Pressure <input type="checkbox"/> Wheel Lugs & Covers* <input type="checkbox"/> Stabilizer Jack Operation* <input type="checkbox"/> Tent - Fit & Finish <input type="checkbox"/> Clean & Free of Damage* <input type="checkbox"/> Entry Doors* <input type="checkbox"/> Entry Step <input type="checkbox"/> Compartment Doors* <input type="checkbox"/> Frame Condition <input type="checkbox"/> Spare Tire - If installed <input type="checkbox"/> All Roof Seams, Doors & Body Joints Properly Sealed <input type="checkbox"/> Exterior Range & Table Mount	<p>WATER SYSTEM</p> <input type="checkbox"/> Galley Hand Pump <input type="checkbox"/> City Water <input type="checkbox"/> Functions with Pump & City Water Hook-up <input type="checkbox"/> Joints Tight and No Leaks <input type="checkbox"/> Faucets Tight and No Leaks <input type="checkbox"/> All Drains <input type="checkbox"/> Fresh Water Tank Drain <input type="checkbox"/> Winterize, if required <input type="checkbox"/> 12 Volt Pump, if installed <p>INTERIOR</p> <input type="checkbox"/> Window Operation* <input type="checkbox"/> Emergency Exits* <input type="checkbox"/> Drapes & Curtains <input type="checkbox"/> Cabinets, Fit, Finish & Operation* <input type="checkbox"/> Doors* <input type="checkbox"/> Drawers* <input type="checkbox"/> Counter Tops <input type="checkbox"/> Shelves <input type="checkbox"/> Clothes Rods <input type="checkbox"/> Furniture* <input type="checkbox"/> Dinette <input type="checkbox"/> Beds <input type="checkbox"/> Vents <input type="checkbox"/> Carpet <input type="checkbox"/> Clean & Free of Damage <input type="checkbox"/> Ice Box <p>110V ELECTRICAL</p> <input type="checkbox"/> Power Cord <input type="checkbox"/> Circuit Breakers <input type="checkbox"/> GFI Receptacle if installed <input type="checkbox"/> Refrigerator if installed <input type="checkbox"/> 110 Volt Outlets	<p>CUSTOMER FAMILIARIZATION</p> <input type="checkbox"/> Unit Functions Properly <input type="checkbox"/> Lifter System <input type="checkbox"/> Bed Support Poles <input type="checkbox"/> Tent Rafter Poles <input type="checkbox"/> Brakes-when applicable <input type="checkbox"/> Awning-when applicable <input type="checkbox"/> Operation of all Features demonstrated to Customer <input type="checkbox"/> Stove & Table Placement <input type="checkbox"/> Operation of All Appliances & Accessories <input type="checkbox"/> All Owners Manuals & Warranties <input type="checkbox"/> All Keys <input type="checkbox"/> Customer Understands Warranty and Owner Maintenance Procedures (Initial Below) <input type="checkbox"/> Customer Initial
*Note: Adjustment may be required		
All items listed on the above checklist have been completed by the undersigned dealer to my satisfaction. I have accepted this unit on the date indicated, in satisfactory and usable condition.		
_____ Dealer Signature		_____ Date
_____ Customer Signature		_____ Date
WHITE - Forest River • GREEN - Forest River • PINK - Dealer • YELLOW - Owner		

Forest River, Inc.
P.O. Box 124 • Goshen, IN 46527